

DMX pre-selected range

Mechanical dosing pumps

50 Hz



be
think
innovate

GRUNDFOS 

1. Product introduction	3
Features and benefits	3
Performance range	4
2. Identification	5
Type key	5
3. Construction	6
General information	6
Sectional drawings	7
4. Technical data	8
Weights	8
Motor power	8
Pump protection and efficiency class	8
Sound pressure	8
Accuracy	8
Dimensions	9
5. Pump selection	10
Performance data	10
Pump selection	11
Maintenance kits	12
6. Selection of accessories	13
7. Pumped liquids	14
8. Grundfos Product Center	15

1. Product introduction

Features and benefits

DMX pre-selected range is the fast lane to reliable, tough and well-proven DMX dosing pumps up to 765 l/h.



TM06 8256 0317

Fig. 1 DMX 221 and DMX 226 pre-selected products

The perfect choice

DMX mechanical diaphragm dosing pumps have proven their worth in dosing applications worldwide. The DMX pre-selected range in the product portfolio of mechanical diaphragm dosing pumps covers the most common applications with a wide performance range from 16 l/h (12 bar) to 765 l/h (3 bar) and a variety of accessories.

DMX pre-selected products can be chosen easily and delivered quickly. If necessary, they can be replaced simply and quickly.

Materials of housing and wetted parts

DMX 221 pre-selected products have PPE housings offering chemical resistance and all the protection necessary for many applications. DMX 226 pre-selected products have a robust cast-aluminium housing with epoxy coating to meet all application needs. Even covered outdoor installation is no problem. The parts that are wetted by the dosing medium are made of PVC, ceramics, glass, stainless steel, EPDM, FKM and PTFE. Thanks to the thorough combination of materials, your investment costs and running costs for spare parts are kept low over the years.

Accessories for the entire system

DMX 221 pre-selected products up to 50 l/h (DN 8) are optionally available with a suitable installation set comprising pump connections, hoses, foot valve and injection unit.

A wide range of accessories specially designed for the DMX dosing pumps helps optimise performance. We offer accessories such as pressure loading valves, pressure relief valves and pulsation dampers.

Accurate dosing - all the time

The diaphragm design makes sure, that the dosing flow fluctuation and the linearity deviation are very low. This allows very precise dosing of chemicals - as much as necessary, as little as possible.

Smooth and low-pulsation dosing

Sophisticated drive technology and gear kinematics ensure smooth and low-pulsation dosing without pressure peaks. This means less stress to all system components, such as tubes and valves, and leads to longer service intervals for the entire system.

Applications

Tasks like disinfection, coagulation, flocculation, precipitation in various application fields:

- Drinking water treatment
- Waste water treatment
- Pulp and paper industry
- Textile industry
- Cleaning water treatment
- Food and beverage industry, dairies
- Cooling tower water treatment
- Low-pressure boiler feed water treatment
- Irrigation
- Agriculture.

Performance range

DMX 221 pre-selected products

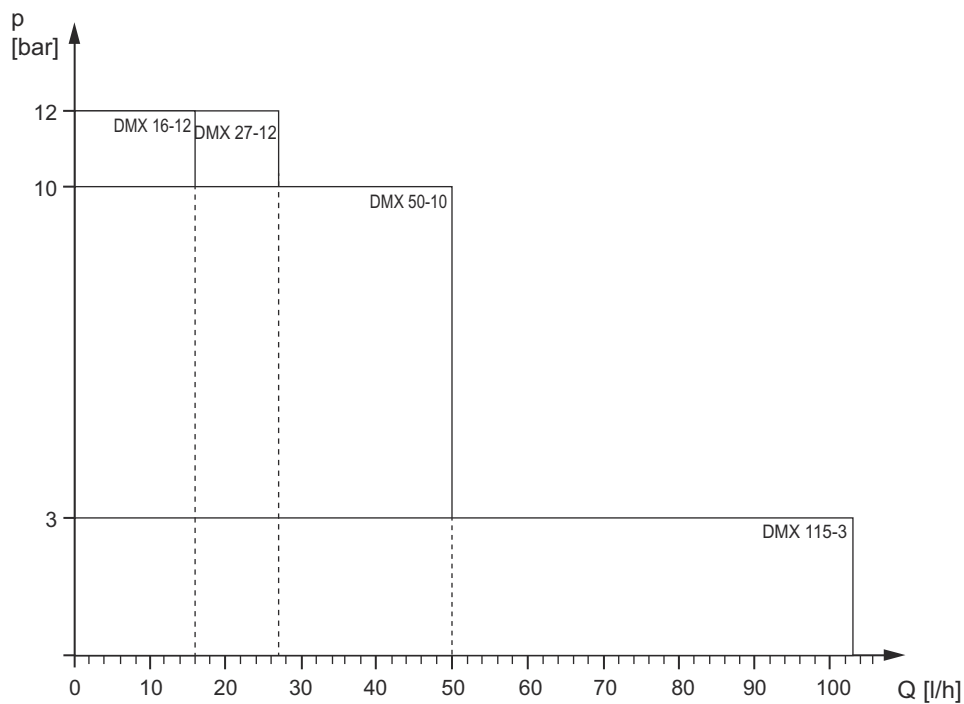

Fig. 1 DMX 221 pre-selected products performance range

DMX 226 pre-selected products

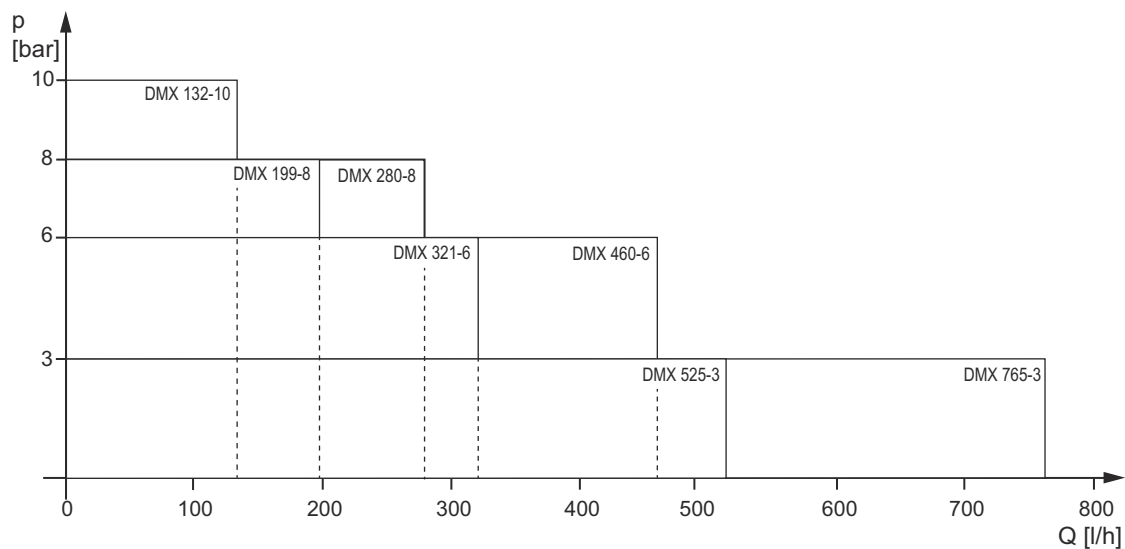

Fig. 2 DMX 226 pre-selected products performance range

TM06 8302 5116

TM06 8165 1117

2. Identification

Type key

Example: DMX 16-12 B-PVC/V/C-X-E1I007

	Code	Description	Remark
Type	DMX	Motor-driven diaphragm dosing pump	
Maximum flow	16	16 l/h maximum capacity of the pump	Example
Maximum pressure	12	Maximum counterpressure 12 bar	Example
Number of dosing heads		Single-head	
Control variant	B	Standard (manual control)	
Dosing head variant	PVC	Polyvinyl Chloride	
Gasket material	E	EPDM	
	V	FKM	
Valve ball material	G	Glass	
	C	Ceramic	
	SS	Stainless steel, 1.4401 (EN 10027-2), 316Ti (AISI)	
Control panel position	X	No control panel (without AR, without VFD)	
Supply voltage	E	3 x 230/400 V, 50/60 Hz; 3 x 440/480 V, 60 Hz	
	G	1 x 220-240 V 50/60 Hz 1 x 230 V, 50 Hz	DMX 221 DMX 226
Valve type	1	Standard, not spring-loaded (inlet/outlet side)	
Connection, inlet/outlet / Installation set	I007	Installation set Including 2 pump connections, foot valve, injection unit, 6 m PVC outlet hose (6/12 mm), 2 m PVC inlet hose (6/12 mm)	DMX 221 up to 50 l/h
	U2	PVC, G 5/8, for hose 4/6 mm, 6/9 mm, 6/12 mm, 9/12 mm	DMX 221 up to 50 l/h, DN 8
	U3	PVC, G 5/4, for 19/27 mm hose and Ø25 pipe	DMX 226 up to 460 l/h; DMX 221: 115-3, DN 20
	K	PVC, G 2, for Ø40 pipe	DMX 226: 525-3, 765-3, DN 32
Mains plug	-	No cable, no plug for 3 AC motors	DMX 226
	X	No plug for 1 AC motors and with AR	DMX 221
Motor variant	-	Standard motor	

3. Construction

General information

Grundfos DMX pumps are mechanical diaphragm dosing pumps. The strokes are generated by an eccentric, which moves the diaphragm by means of a tappet. The discharge stroke is activated by the eccentric, the suction stroke is activated by the spring return. DMX pre-selected products are designed for capacities between 16 l/h and 765 l/h, and a maximum pressure of up to 12 bar. They have a separation chamber, which prevents the pumped liquid from flooding the pump or other system components in the event of a diaphragm failure.

The motor design allows perpetual switching on and off without overheating.

Capacity control by stroke-length adjustment

The capacity is controlled by means of the stroke-length adjustment knob, or electrically by a servomotor. The stroke frequency remains constant.

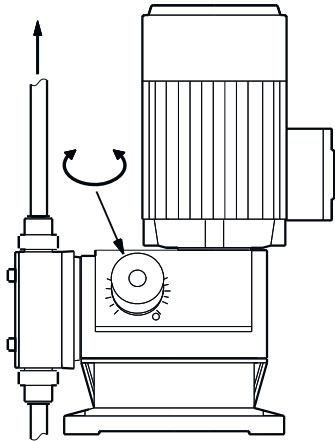

Fig. 3 Capacity control by stroke-length adjustment knob

Functional principle

- Reciprocating displacement pump with electric motor and mechanical diaphragm control.
- The rotation of the motor is transformed into the reciprocating movement of the dosing diaphragm by the operation of the eccentric and tappet.
- Adjustment of the dosing flow is possible by adjusting the stroke length.

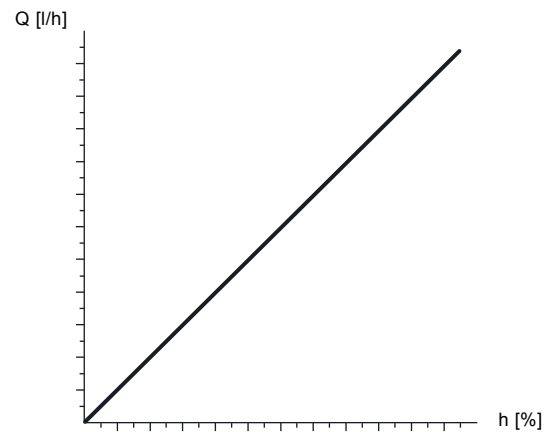

Fig. 4 Relation of stroke length and capacity

Capacity setting

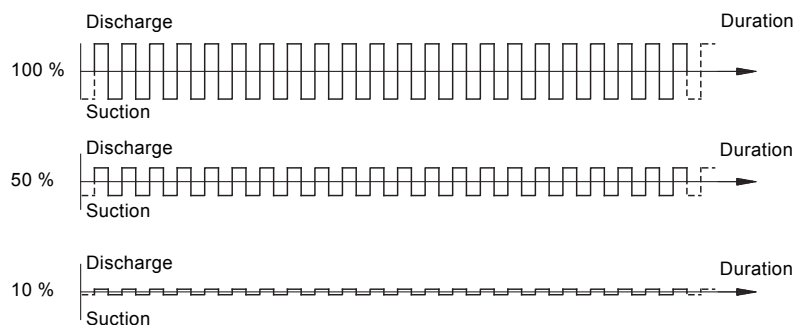

Fig. 5 Relation of stroke-length adjustment - capacity

Sectional drawings

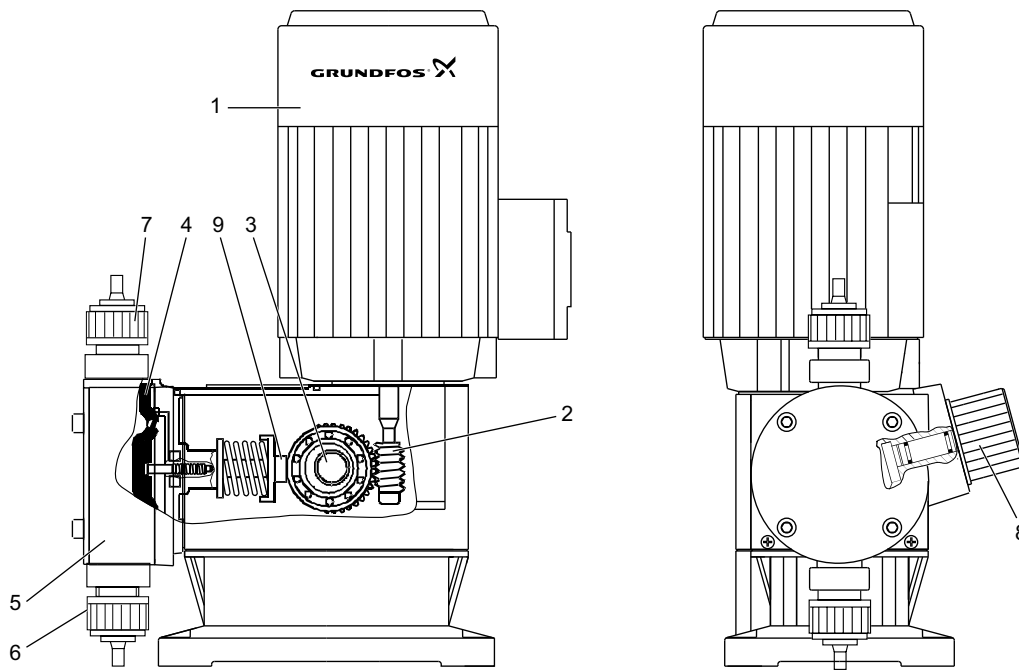

Fig. 6 Sectional drawing DMX 221 pre-selected products

TM04 1559 1310

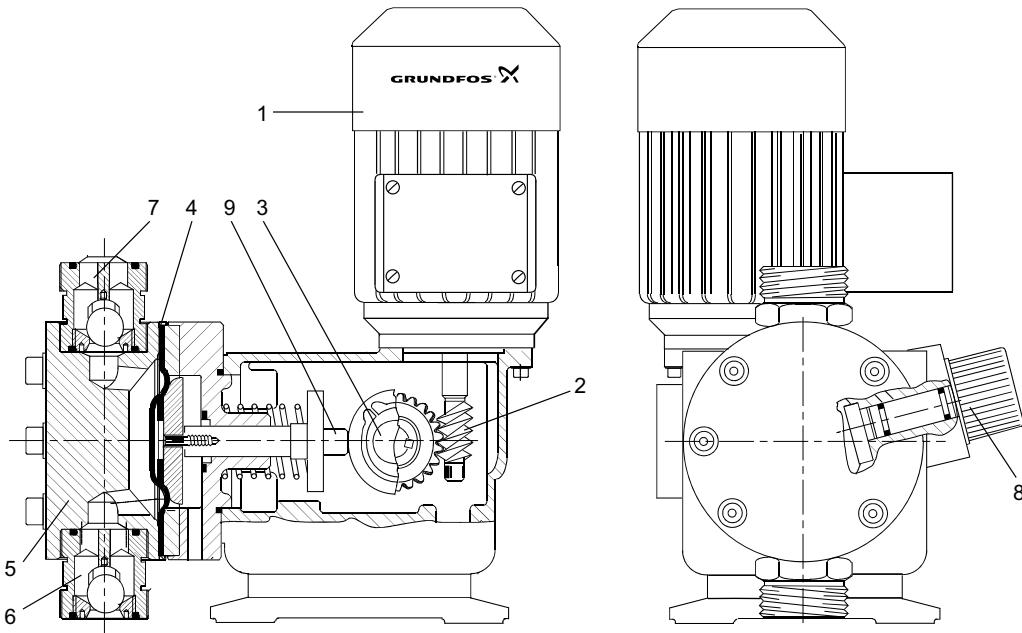

Fig. 7 Sectional drawing DMX 226 pre-selected products

TM03 1869 3805

Pos.	Description
1	Motor
2	Gears
3	Eccentric
4	Dosing diaphragm
5	Dosing head
6	Inlet valve
7	Outlet valve
8	Stroke-length adjustment knob
9	Tappet

4. Technical data

Weights

DMX 221 pre-selected products

Pump type	Weights [kg]
DMX 16-12	7-11
DMX 27-12	7-11
DMX 50-10	7-12
DMX 115-3	10-15

The weights are approximate.

DMX 226 pre-selected products

Pump type	Weights [kg]
DMX 132-10	18
DMX 199-8	18
DMX 280-8	18
DMX 321-6	19
DMX 460-6	19
DMX 525-3	23
DMX 765-3	23

The weights are approximate.

Motor power

DMX pre-selected products	Capacity [l/h]	Motor power [kW]		
		50 Hz	1 AC	3 AC
221	16, 27	0.09	1	0.5
221	50, 115	0.09	1	0.5
226	All	0.37	3	1.2

* Nominal current according to the nameplate of the motor

Pump protection and efficiency class

The motor protection defines the pump protection class.

- protection rating: IP65.

Sound pressure

- sound pressure level: 55 dB(A).

The sound pressure level was tested according to DIN 45635-01-KL3.

Accuracy

- dosing flow fluctuation: $\pm 1.5\%$ of full-scale value
- linearity deviation: $\pm 4\%$ of full-scale value within 20-100 % stroke length.

The values are based on the following conditions: water as dosing liquid, fully vented dosing head and pump version with 3 AC motor.

Ambient and operating conditions for DMX 221 and DMX 226 pre-selected products

- permissible temperature of dosing liquid: 0 °C to +40 °C
- permissible ambient temperature: 0 °C to +40 °C
- permissible storage temperature: -20 °C to +50 °C
- max. relative humidity (non-condensing): 70 % at +40 °C, 90 % at +35 °C.

Dimensions

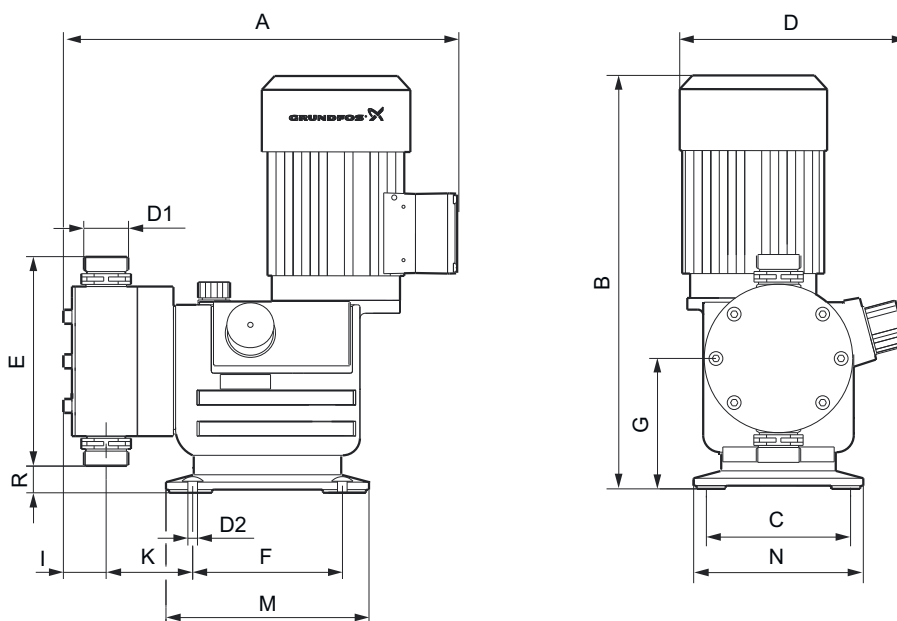

Fig. 8 Dimensions, DMX 221, 226

TM06 8844 1217

DMX 221 pre-selected products

Pump type	A [mm]	B [mm]	C [mm]	D [mm]	D1 [inch]	D2 [mm]	E [mm]	F [mm]	G [mm]	I [mm]	K [mm]	M [mm]	N [mm]	R [mm]
DMX 16-12														
DMX 27-12	279	358	105	175	G 5/8	6.5	153	159	102	25	38	180	123	26
DMX 50-10														
DMX 115-3	333	358	105	175	G 1 1/4	6.5	189	159	102	40	76	180	123	9

DMX 226 pre-selected products

Pump type	A [mm]	B [mm]	C [mm]	D [mm]	D1 [inch]	D2 [mm]	E [mm]	F [mm]	G [mm]	I [mm]	K [mm]	M [mm]	N [mm]	R [mm]
DMX 132-10, 3AC	345	399	136	214										
DMX 132-10, 1AC	368.5	434	136	227	G 1 1/4	9	178	140	123	38	81	190	160	34
DMX 199-8, 3AC	348	399	136	214										
DMX 199-8, 1AC	371.2	434	136	227	G 1 1/4	9	188	140	123	40	81.7	190	160	29
DMX 280-8, 3AC	348	399	136	214										
DMX 280-8, 1AC	371.2	434	136	227	G 1 1/4	9	188	140	123	40	81.7	190	160	29
DMX 321-6, 3AC	353	399	136	214										
DMX 321-6, 1AC	380	434	136	227	G 1 1/4	9	209	140	123	41.5	86	190	160	19
DMX 460-6, 3AC	353	399	136	214	G 1 1/4	9	209	140	123	41.5	86	190	160	19
DMX 525-3, 3AC	373	399	136	214	G 2	9	242	140	123	54	93	190	160	2
DMX 765-3, 3AC	373	399	136	214	G 2	9	242	140	123	54	93	190	160	2

5. Pump selection

1. Choose a DMX pre-selected product from the *Performance data* tables.
 2. Look into the *Pump selection* tables to find the suitable product number.
- If you cannot find a DMX pre-selected product for your application needs, select a suitable variant from the DMX make-to-order range.

Performance data

The values in the tables are based on the following conditions:

- 50 Hz
- flooded suction: 0.5 m
- fully vented dosing head
- 400 V motor, 3-phase
- liquid with viscosity similar to water
- minimum counterpressure: 1 bar.

The counterpressure refers to the pressure at the pump outlet valve. Pressure losses in the line to the injection point are not taken into account.

The maximum permissible viscosity at operating temperature applies to:

- Newtonian fluids
- non-degassing media
- media without suspended matter
- media with a density similar to water.

Note: The viscosity increases with decreasing temperature! We recommend to test the performance with the respective liquid.

DMX 221 pre-selected products

Max. capacity ¹⁾	Max. pressure	Pump type	Connection inlet/outlet	Stroke frequency	Stroke volume	Max. suction lift ¹⁾	Max. suction lift (max. viscosity)	Max. length of inlet line	Max. viscosity
[l/h]	[bar]			[n/min]	[ml]	[m]	[m]	[m]	[mPas]
16	12	DMX 16-12	DN 8	120	2.2	4	1	5	200
27	12	DMX 27-12	DN 8	120	3.8	1	1	5	200
50	10	DMX 50-10	DN 8	120	6.9	3	1	4	100
115	3	DMX 115-3	DN 20	120	16	1	0	2	100

¹⁾ Viscosity similar to water

DMX 226 pre-selected products

Max. capacity ¹⁾	Max. pressure	Pump type	Connection inlet/outlet	Stroke frequency	Stroke volume	Max. suction lift ¹⁾	Max. suction lift (max. viscosity)	Max. length of inlet line	Max. viscosity
[l/h]	[bar]			[n/min]	[ml]	[m]	[m]	[m]	[mPas]
132	10	DMX 132-10	DN 20	120	18.5	3	1	4	400
199	8	DMX 199-8	DN 20	120	27.8	3	0	3	200
280	8	DMX 280-8	DN 20	175	27.8	2	0	3	100
321	6	DMX 321-6	DN 20	120	44.6	0	0	3	100
460	6	DMX 460-6	DN 20	175	44.6	0	0	3	100
525	3	DMX 525-3	DN 32	120	73	1	0	2	50
765	3	DMX 765-3	DN 32	175	73	0	0	2	10

¹⁾ Viscosity similar to water

Pump selection

DMX 221 pre-selected products

- valves: standard
- connections:
 - up to 50 l/h: Hose 6/9 mm, 6/12 mm, 9/12 mm (DN 8)
 - 115 l/h: Hose 19/27 mm, pipe cementing D25 (DN 20)

Max. flow [l/h]	Max. pressure [bar]	Materials			Installation set	Type designation	Product number	
		Dosing head	Gaskets	Valve balls			Supply voltage	
							G 1 AC 230 V 50/60 Hz	E 3 AC 230/400 V 50/60 Hz
16	12	PVC	FKM	Ceramic	No	DMX 16-12 B-PVC/N/C-X-E1U2U2	99206065	99205916
					Yes	DMX 16-12 B-PVC/N/C-X-E1I007	99206066	99205965
		PVC	EPDM	Ceramic	No	DMX 16-12 B-PVC/E/C-X-E1U2U2	99206067	99205971
					Yes	DMX 16-12 B-PVC/E/C-X-E1I007	99206068	99205972
27	12	PVC	FKM	Ceramic	No	DMX 27-12 B-PVC/N/C-X-E1U2U2	99206069	99205993
					Yes	DMX 27-12 B-PVC/N/C-X-E1I007	99206070	99205994
		PVC	EPDM	Ceramic	No	DMX 27-12 B-PVC/E/C-X-E1U2U2	99206071	99205995
					Yes	DMX 27-12 B-PVC/E/C-X-E1I007	99206072	99205997
50	10	PVC	FKM	Ceramic	No	DMX 50-10 B-PVC/N/C-X-E1U2U2	99206073	99205998
					Yes	DMX 50-10 B-PVC/N/C-X-E1I007	99206075	99205999
		PVC	EPDM	Ceramic	No	DMX 50-10 B-PVC/E/C-X-E1U2U2	99206076	99206000
					Yes	DMX 50-10 B-PVC/E/C-X-E1I007	99206077	99206001
115	3	PVC	FKM	Ceramic	No	DMX 115-3 B-PVC/N/G-X-E1U3U3	99206078	99206002
		PVC	EPDM	Ceramic	No	DMX 115-3 B-PVC/E/G-X-E1U3U3	99206081	99206003

DMX 226 pre-selected products

- valves: standard
- connections:
 - up to 460 l/h: Hose 19/27 mm, pipe cementing D25 (DN 20)
 - 525 l/h and 765 l/h: Pipe cementing D40 (DN 32)

Max. flow [l/h]	Max. pressure [bar]	Materials			Type designation	Product number	
		Dosing head	Gaskets	Valve balls		Supply voltage	
						G 1 AC 230 V 50/60 Hz	E 3 AC 230/400 V 50/60 Hz
132	10	PVC	FKM	Ceramic	DMX 132-10 B-PVC/N/C-X-E1U3U3	99206047	99206011
		PVC	EPDM	Ceramic	DMX 132-10 B-PVC/E/C-X-E1U3U3	99206048	99206033
199	8	PVC	FKM	Ceramic	DMX 199-8 B-PVC/N/C-X-E1U3U3	99206049	99206034
		PVC	EPDM	Ceramic	DMX 199-8 B-PVC/E/C-X-E1U3U3	99206050	99206035
280	8	PVC	FKM	Ceramic	DMX 280-8 B-PVC/N/C-X-E1U3U3	99206051	99206036
		PVC	EPDM	Ceramic	DMX 280-8 B-PVC/E/C-X-E1U3U3	99206052	99206037
321	6	PVC	FKM	Ceramic	DMX 321-6 B-PVC/N/C-X-E1U3U3	99206063	99206038
		PVC	EPDM	Ceramic	DMX 321-6 B-PVC/E/C-X-E1U3U3	99206064	99206039
460	6	PVC	FKM	Ceramic	DMX 460-6 B-PVC/N/C-X-E1U3U3	-	99206040
		PVC	EPDM	Ceramic	DMX 460-6 B-PVC/E/C-X-E1U3U3	-	99206042
525	3	PVC	FKM	Glass	DMX 525-3 B-PVC/N/G-X-E1KK	-	99206043
		PVC	EPDM	SS	DMX 525-3 B-PVC/E/SS-X-E1KK	-	99206044
765	3	PVC	FKM	Glass	DMX 765-3 B-PVC/N/G-X-E1KK	-	99206045
		PVC	EPDM	SS	DMX 765-3 B-PVC/E/SS-X-E1KK	-	99206046

Maintenance kits

DMX 221 pre-selected

Pump type	Max. flow 50 Hz [l/h]	Max. pressure 50 Hz [bar]	Gasket	Valve balls	Product number			
					1 valve	2 valves, 1 diaphragm	1 diaphragm	Dosing head
DMX 16-12	16	12	FKM	Ceramic	98798542	99079236	99145975	98808112
			EPDM	Ceramic	98798550	99200223		
DMX 27-12	27	12	FKM	Ceramic	98798542	99079184	99145976	98808114
			EPDM	Ceramic	98798550	99200231		
DMX 50-10	50	10	FKM	Ceramic	98798542	99079233	99145979	98808116
			EPDM	Ceramic	98798550	99200232		
DMX 115-3	115	3	FKM	Ceramic	98828462	99070262	99145996	98808118
			EPDM	Ceramic	98794843	99200233		

DMX 226 pre-selected

Pump type	Max. flow 50 Hz [l/h]	Max. pressure 50 Hz [bar]	Gasket	Valve balls	Product number			
					1 valve	2 valves, 1 diaphragm	1 diaphragm	Dosing head
DMX 132-10	132	10	FKM	Ceramic	98828462	98827341	98922727	98808117
			EPDM	Ceramic	98794843	98965729		
DMX 199-8	199	8	FKM	Ceramic	98828462	98827244	98922728	98808118
			EPDM	Ceramic	98794843	98965765		
DMX 280-8	280	8	FKM	Ceramic	98828462	98827244	98922728	98808118
			EPDM	Ceramic	98794843	98965765		
DMX 321-6	321	6	FKM	Ceramic	98828462	98827344	98922729	98808120
			EPDM	Ceramic	98794843	98965761		
DMX 460-6	460	6	FKM	Ceramic	98828462	98827344	98922729	98808120
			EPDM	Ceramic	98794843	98965761		
DMX 525-3	525	3	FKM	Glass	98812754	98871193	98922730	98808121
			EPDM	SS	98802231	98871194		
DMX 765-3	765	3	FKM	Glass	98812754	98871193	98922730	98808121
			EPDM	SS	98802231	98871194		

6. Selection of accessories

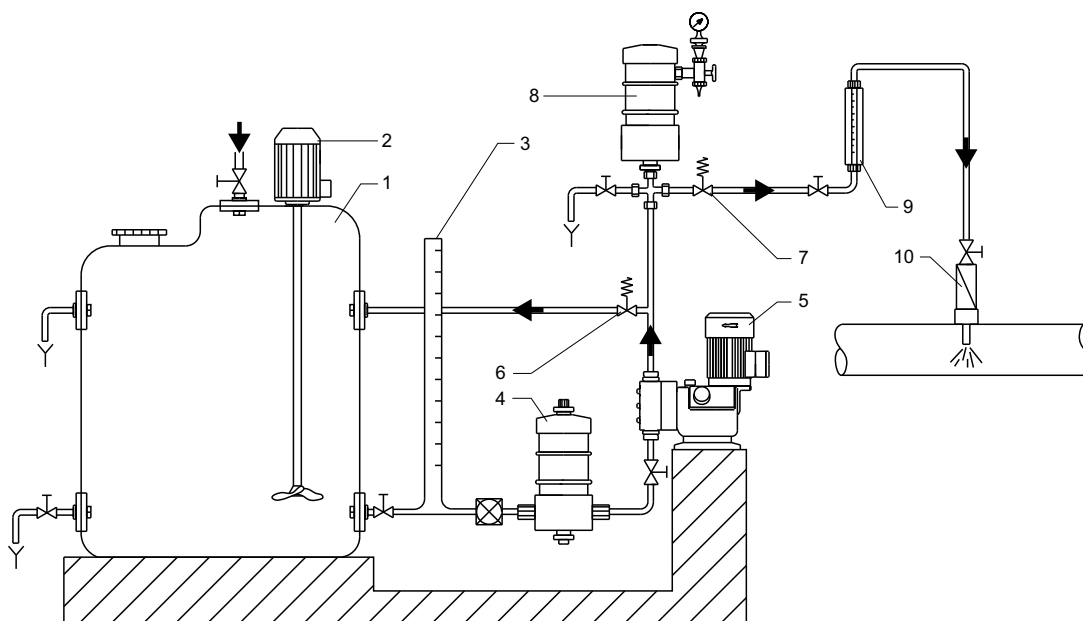

TM03 2124 3705

Fig. 9 Overview of a dosing system

Legend

Pos.	Component
1	Dosing tank
2	Electric stirrer
3	Lateral discharge device
4	Pulsation damper, inlet-side
5	Dosing pump
6	Pressure relief valve
7	Pressure-loading valve
8	Pulsation damper, outlet-side
9	Measuring glass
10	Injection unit

Installation set

An installation set includes the following parts:

- pump connections for inlet and outlet valve
- injection unit with spring-loaded non-return valve
- PVC outlet hose (6/12 mm), 6 m
- PVC inlet hose (6/12 mm), 2 m
- foot valve with strainer and weight.



Fig. 10 Installation set

Other installation sets are available from our wide range of pump accessories.

TM06 9192 1817

DMX 221 pre-selected products

Pump type	Connection size	Suitable accessories
DMX 27-12 DMX 16-12 DMX 50-10	DN 8	Accessories for small dosing pumps
DMX 115-3	DN 20	Accessories for medium sized dosing pumps

DMX 226 pre-selected products

Pump type	Connection size	Accessories chapter
DMX 132-10 DMX 199-8 DMX 280-8 DMX 321-6 DMX 460-6	DN 20	Accessories for medium sized dosing pumps
DMX 525-3 DMX 765-3	DN 32	Accessories for large dosing pumps

Pump accessories

Find the suitable accessories for your application needs.



Data booklet Pump accessories

<http://net.grundfos.com/qr/i/96700284>

7. Pumped liquids

The resistance table below is intended as a general guide for material resistance (at room temperature), and does not replace testing of the chemicals and pump materials under specific working conditions.

The data shown are based on information from various sources available, but many factors (purity, temperature, abrasive particles, etc.) may affect the chemical resistance of a given material.

Note: Some of the liquids in this table may be toxic, corrosive or hazardous. Please be careful when handling these liquids.

Pumped liquid (20 °C)			Material					
			Dosing head	Gasket		Valve ball		
Description	Chemical formula	Concentration [%]	PVC	FKM	EPDM	Ceramic	Glass	SS 1.4401
Acetic acid	CH ₃ COOH	25	•	-	•	•	•	•
		60	•	-	•	•	•	•
		85	-	-	-	•	•	○
Aluminium chloride	AlCl ₃	40	•	•	•	•	•	-
Aluminium sulphate	Al ₂ (SO ₄) ₃	60	•	•	•	•	-	•
Ammonia, aqueous	NH ₄ OH	28	•	-	•	•	-	•
Calcium hydroxide ⁵⁾	Ca(OH) ₂		•	•	•	•	•	•
Calcium hypochlorite	Ca(OCl) ₂	20	•	•	•	•	•	-
		10	•	•	•	•	•	•
		30	•	•	○	•	•	-
Chromic acid ³⁾	H ₂ CrO ₄	50	•	•	-	•	•	-
		30	•	•	○	•	•	-
		10	•	•	-	•	•	-
Copper sulphate	CuSO ₄	30	•	•	•	•	•	•
Ferric chloride ¹⁾	FeCl ₃	45	•	•	•	•	•	-
Ferric sulphate ¹⁾	Fe ₂ (SO ₄) ₃	60	•	•	•	•	•	○
Ferrous chloride	FeCl ₂	37	•	•	•	•	•	-
Ferrous sulphate	FeSO ₄	30	•	•	•	•	•	•
Fluosilicic acid	H ₂ SiF ₆	40	•	-	○	•	-	○
Hydrochloric acid	HCl	< 25	•	•	•	•	•	-
		25-37	•	•	○	•	•	-
Hydrogen peroxide	H ₂ O ₂	30	•	•	•	•	•	•
		30	•	•	•	•	•	•
Nitric acid	HNO ₃	40	•	•	-	•	•	•
		70	-	•	-	•	•	•
		30	○	-	○	•	•	○
Potassium hydroxide	KOH	50	•	-	•	•	-	•
Potassium permanganate	KMnO ₄	10	•	○	•	•	•	•
Sodium chlorate	NaClO ₃	30	•	•	•	•	•	•
Sodium chloride	NaCl	30	•	•	•	•	•	-
Sodium chlorite	NaClO ₂	20	○	•	•	•	•	-
		20	•	•	•	•	-	-
		30	•	○	•	•	-	•
Sodium hydroxide	NaOH	50	•	-	•	•	-	•
		30	•	○	•	•	-	•
		12-15	•	•	•	•	-	-
Sodium hypochlorite	NaOCl	12-15	•	•	•	•	-	-
Sodium sulphide	Na ₂ S	30	•	•	•	•	-	•
Sodium sulphite	Na ₂ SO ₃	20	•	•	•	•	-	•
Sodium thiosulfate	Na ₂ S ₂ O ₃	10	•	•	•	•	•	•
Sulphurous acid	H ₂ SO ₃	6	•	•	•	•	○	•
		< 80	•	•	○	•	○	-
		80-96	•	•	-	•	-	-
Sulphuric acid ²⁾	H ₂ SO ₄	98	-	○	-	•	-	•

• Resistant

○ Limited resistance

- Not resistant

¹⁾ Risk of crystallisation

²⁾ Reacts violently with water and generates much heat (pump should be absolutely dry before dosing sulphuric acid)

³⁾ Must be fluoride-free when glass balls are used

⁵⁾ Once the pump is stopped, calcium hydroxide will sediment rapidly

Further information: <http://product-selection.grundfos.com/liquids.html>

8. Grundfos Product Center

Online search and sizing tool to help you make the right choice.

<http://product-selection.grundfos.com>



SIZING enables you to size a pump based on entered data and selection choices.

REPLACEMENT enables you to find a replacement product. Search results will include information on

- the lowest purchase price
- the lowest energy consumption
- the lowest total life cycle cost.

The screenshot shows the Grundfos Product Center website. At the top, there is a navigation bar with the logo, 'PRODUCT CENTER', and user options like 'Login'. Below this is a search bar with a 'SEARCH' button. A main menu includes 'HOME', 'FIND PRODUCT', 'COMPARE', 'YOUR PROJECTS', 'SAVED ITEMS', and 'HELP'. The main content area features four large buttons: 'SIZING' (with a subtext 'Enter pump sizing'), 'CATALOGUE' (with a subtext 'Products and services'), 'REPLACEMENT' (with a subtext 'Replace an old pump with a new'), and 'LIQUIDS' (with a subtext 'Find pump by liquid'). Below these is a 'QUICK SIZING' section with input fields for 'Flow (Q)*' and 'Head (H)*', a 'Select what to size by' section with radio buttons for 'Size by application', 'Size by pump design', and 'Size by pump family', and a 'START SIZING' button. At the bottom of this section, there are options for 'ADVANCED SIZING' with checkboxes for 'Advanced sizing by application' and 'Guided selection'. Callout boxes provide detailed descriptions for the SIZING, REPLACEMENT, CATALOGUE, and LIQUIDS features.

SIZING enables you to size a pump based on entered data and selection choices.

REPLACEMENT enables you to find a replacement product. Search results will include information on

- the lowest purchase price
- the lowest energy consumption
- the lowest total life cycle cost.

CATALOGUE gives you access to the Grundfos product catalogue.

LIQUIDS enables you to find pumps designed for aggressive, flammable or other special liquids.

All the information you need in one place

Performance curves, technical specifications, pictures, dimensional drawings, motor curves, wiring diagrams, spare parts, service kits, 3D drawings, documents, system parts. The Product Center displays any recent and saved items - including complete projects - right on the main page.

Downloads

On the product pages, you can download installation and operating instructions, data booklets, service instructions, etc. in PDF format.

Subject to alterations.

be think innovate

99204143 0517

ECM: 1198593

GRUNDFOS A/S
DK-8850 Bjerringbro . Denmark
Telephone: +45 87 50 14 00
www.grundfos.com

GRUNDFOS 

© Copyright Grundfos Holding A/S

The name Grundfos, the Grundfos logo, and be think innovate are registered trademarks owned by Grundfos Holding A/S or Grundfos A/S, Denmark. All rights reserved worldwide.