

Thermal Oil / Hot Water Pump

Etabloc SYT

Fixed Speed / Variable Speed
50 Hz / 60 Hz

Type Series Booklet



Legal information/Copyright

Type Series Booklet Etabloc SYT

All rights reserved. The contents provided herein must neither be distributed, copied, reproduced, edited or processed for any other purpose, nor otherwise transmitted, published or made available to a third party without the manufacturer's express written consent.

Subject to technical modification without prior notice.

© KSB SE & Co. KGaA, Frankenthal 21/09/2020

Contents

Centrifugal Pumps with Shaft Seal.....	4
Thermal Oil Pumps / Hot Water Pumps	4
Etabloc SYT	4
Main applications.....	4
Fluids handled	4
Further information on fluids handled.....	4
Related documents	4
Operating data.....	4
Design details	5
Designation	7
Materials.....	8
Coating and preservation	8
Product benefits	8
Acceptance tests and warranty	8
Overview of product features / selection tables	9
Overview of variants	9
Overview of fluids handled	10
Overview of functions.....	11
Pressure and temperature limits	13
Technical data	13
Etabloc SYT	13
Selection charts	14
Etabloc SYT (fixed speed version), n = 2900 rpm	14
Etabloc SYT (fixed speed version), n = 1450 rpm	14
Etabloc SYT (fixed speed version), n = 3500 rpm	15
Etabloc SYT (fixed speed version), n = 1750 rpm	15
Dimensions and connections	16
Pump set (fixed speed version), n = 2900 rpm / 3500 rpm.....	16
Pump set (fixed speed version), n = 1450 rpm / 1750 rpm.....	20
Connections.....	23
Flange design	24
Installation types.....	25
Scope of supply	25
General assembly drawings.....	26
Etabloc SYT exploded view.....	26

Centrifugal Pumps with Shaft Seal

Thermal Oil Pumps / Hot Water Pumps

Etabloc SYT



Main applications

- Heat transfer systems
- Hot water circulation

Fluids handled

- High-temperature hot water
- Thermal oil, mineral
- Thermal oil, synthetic

Further information on fluids handled

Overview of fluids handled (⇒ Page 10)

Related documents

Information/documents

Document	Reference number
Characteristic curves booklet (50 Hz) Fixed speed version	1311.45
Characteristic curves booklet (60 Hz) Fixed speed version	1311.46
Type series booklet KSB SuPremE	4075.53
Type series booklet PumpDrive 2 / PumpDrive 2 Eco	4074.5

Operating data

Operating properties in standard applications

Characteristic	Value	Value	
		50 Hz	60 Hz
Flow rate	Q [m ³ /h]	≤ 280	≤ 337
Head	H [m]	≤ 68	≤ 99
Fluid temperature	T [°C]	≥ -30	≥ -30
Thermal oil (mineral / synthetic)		≤ +350	≤ +350
Fluid temperature		≤ +180	≤ +180
Hot water			
Operating pressure	p [bar]	≤ 16	≤ 16

Operating properties in marine applications, to DNV GL

Characteristic	Value	Value		
		Class I ¹⁾	Class II ²⁾	Class III ³⁾
Steam				
Design pressure	p [bar]	> 16	≤ 16	≤ 7
Design temperature	T [°C]	> 300	≤ 300	≤ 170
Thermal oil				
Design pressure	p [bar]	> 16	≤ 16	≤ 7
Design temperature	T [°C]	> 300	≤ 300	≤ 150
Fuel oil, lubricating oil, combustible hydraulic oil				
Design pressure	p [bar]	> 16	≤ 16	≤ 7
Design temperature	T [°C]	> 150	≤ 150	≤ 60
Other fluids ⁴⁾				
Design pressure	p [bar]	> 40	≤ 40	≤ 16
Design temperature	T [°C]	> 300	≤ 300	≤ 200

Loading pipes for flammable liquids on offshore supply vessels belong to the same piping class as the fuel. Class II piping suffices outside of category A engine rooms.

Pipes for toxic or corrosive fluids belong to piping class I.

Loading pipes for chemicals or liquefied gases are not specified in the table.

¹ At least one condition must be met for class I piping (design pressure or design temperature).

² Both conditions must be met for class II piping (design pressure and design temperature).

³ Both conditions must be met for class III piping (design pressure and design temperature).

⁴ Cargo oil pipes on oil tankers and open pipe outlets (drains, overflows, ventilation, boiler drain pipes, etc.), irrespective of pressure and temperature, belong to class III.

Design details

Design

- Volute casing pump
- Horizontal installation
- Vertical installation
- Back pull-out design
- Single-stage
- Ratings to EN 733
- Fixed speed version (without PumpDrive 2 / PumpDrive 2 Eco / PumpDrive R) / variable speed version (with PumpDrive 2 / PumpDrive 2 Eco / PumpDrive R)

Pump casing

- Radially split volute casing
- Replaceable casing wear rings
- Volute casing with integrally cast pump feet

Drive (fixed speed version)

Standard design:

- KSB/Siemens surface-cooled IEC frame three-phase squirrel-cage motor
- Efficiency class IE1 (size 71/80) / IE3 (from size 90) to IEC 60034-30
- Rated voltage (50 Hz) 230 V / 400 V \leq 2.20 kW
- Rated voltage (50 Hz) 400 V / 690 V \geq 3.00 kW
- Rated voltage (60 Hz) - / 460 V \leq 2.20 kW
- Rated voltage (60 Hz) 460 V / - \geq 3.00 kW
- Type of construction IM V1
- Enclosure IP55
- Duty cycle: continuous duty S1
- Thermal class F with temperature sensor, 1 PTC thermistor (size 80/90) / 3 PTC thermistors (from size 100)

Explosion-proof design:

- KSB surface-cooled IEC three-phase current squirrel-cage motor
- Efficiency class IE2 / IE3 to IEC 60034-30
- Rated voltage (50 Hz) 230 V / 400 V \leq 2.50 kW
- Rated voltage (50 Hz) 400 V / 690 V \geq 3.30 kW
- Rated voltage (60 Hz) - / 460 V \leq 2.50 kW
- Rated voltage (60 Hz) 460 V / - \geq 3.30 kW
- Type of construction IM V1
- Enclosure IP55
- Duty cycle: continuous duty S1
- II 3G Ex ec IIC T3 Gc
- II 2G Ex eb IIC T3 Gb
- II 2G Ex db (eb) IIB T4 Gb
- II 2G Ex db (eb) IIC T4 Gb

Drive (variable speed version)

KSB SuPremE motor:

- Surface-cooled KSB SuPremE motor, IEC-compatible, magnetless synchronous reluctance motor⁵⁾ (PumpDrive required)
- Efficiency class IE4/IE5 to IEC TS 60034-30-2:2016
- Mounting points to EN 50347:2001
- Envelope dimensions to DIN VDE 42673-4:2011-07
- Type of construction IM V1
- Enclosure IP55
- Duty cycle: continuous duty S1
- Thermal class F with temperature sensor, 3 PTC thermistors
- Shaft centreline height 71 to 225 mm
- Rated power 0.55 kW to 45 kW
- Rated speed 1500 rpm or 3000 rpm
- Frequency 50 Hz / 60 Hz (PumpDrive input)
- Voltage 380 V to 480 V (PumpDrive input)

KSB SuPremE X1:

- With terminal box for connecting to PumpDrive 2 or PumpDrive R for mounting on walls and in control cabinets

KSB SuPremE X2:

- Equipped for being fitted with a motor-mounted PumpDrive 2

PumpDrive 2 / PumpDrive 2 Eco:

- Self-cooling frequency inverter of modular design for the continuously variable speed control of asynchronous motors and synchronous reluctance motors by means of analog standard signals, a field bus or the control panel
- Identical design of frequency inverter for the mounting types motor mounting (only for fluid temperature \leq 110 °C), wall mounting and cabinet mounting
- Mains voltage 3~ 380 V AC -10 % to 480 V AC +10 %
- Mains frequency 50 Hz to 60 Hz \pm 2 %

PumpDrive R:

- Self-cooling frequency inverter of modular design for the continuously variable speed control of asynchronous motors and synchronous reluctance motors, such as KSB SuPremE motors or permanent magnet synchronous motors, by means of analog standard signals, a field bus or the control panel
- Identical design of frequency inverter for the mounting types wall mounting and cabinet mounting
- Mains voltage 3~ 380 V AC -10 % to 480 V AC +10 %
- Extended mains voltage range (on request)
- Mains frequency 50 Hz to 60 Hz \pm 2 %
- Extended power range with a nominal power of 110 kW (standard) or 1400 kW (on request)

Shaft seal

- KSB single mechanical seal
- To EN 12756

Impeller type

- Closed radial impeller with multiply curved vanes

⁵⁾ Motor sizes 0.55 kW / 0.75 kW with 1500 rpm are designed with permanent magnets.

Bearings

- Product-lubricated carbon plain bearings
- Grease-lubricated radial ball bearings in the motor housing

Static sealing elements

- Between volute casing and discharge cover
- Between discharge cover and bearing housing
- Between bearing housing and seal cover

Designation

Designation example

Position																																				
1	2	3	4	5	6	7	8	9	10	11	12	13	14	15	16	17	18	19	20	21	22	23	24	25	26	27	28	29	30	31	32	33	34	35	36	37
E	T	B	Y	0	5	0	-	0	3	2	-	1	6	0	-	5	G	S	D	B	0	8	A	2	1	1	0	0	2	-	-	B	P	D	2	E
See name plate and data sheet																							See data sheet						-							

Designation key

Position	Code	Description
1-4	Pump type	
	ETBY	Etabloc SYT
5-16	Size, e.g.	
	050	Nominal suction nozzle diameter [mm]
	032	Nominal discharge nozzle diameter [mm]
	160	Nominal impeller diameter [mm]
17	Pump casing material	
	S	Nodular cast iron EN-GJS-400-15
18	Impeller material	
	C	Stainless steel 1.4408 / A743CF8M
	G	Cast iron EN-GJL-250 / A48CL35
19	Design	
	D	DNV GL (BT3)
	S	Standard
	X	Non-standard (BT3D, BT3)
20	Casing cover	
	D	Casing cover for Etabloc SYT (dead-end arrangement)
21	Shaft seal type	
	B	Dead-end arrangement, only for Etabloc SYT
22-23	Seal code, single mechanical seal	
	08	AQ1V7GG NU028M0-4EYS
24	Scope of supply	
	A	Pump only (Fig. 0)
	D	Pump, motor
	E	Back pull-out unit
25	Shaft unit	
	2	Shaft unit 25
26-29	Motor rating P _N [kW]	
	0075	7,50

	1320	132,00
30	Number of motor poles	
31-32	Explosion protection	
	ex	With explosion-proof motor
	--	Without explosion-proof motor
33	Product generation	
	B	Etabloc SYT 2014
34-37	Design	
	-	Fixed speed version, without PumpDrive
	PD2	Variable speed version, with PumpDrive 2
	PD2E	Variable speed version, with PumpDrive 2 Eco

Materials

Overview of available materials

Part No. (⇒ Page 26)	Description	Material
102	Volute casing	Nodular cast iron EN-GJS-400-15 / 536 Gr. 60-40-18
161	Casing cover	Nodular cast iron EN-GJS-400-15 / 536 Gr. 60-40-18
210	Shaft	Chrome steel 1.4021 + QT800
230	Impeller	Grey cast iron EN-GJL-250 / A 48 CL 35B
		Chrome steel 1.4408 / A 743 Gr. CF8M
310	Plain bearing	Carbon
341	Drive lantern	Grey cast iron EN-GJL-250 / A 48 CL 35B
350	Bearing housing	Nodular cast iron EN-GJS-400-15 / 536 Gr. 60-40-18
411.10/.15	Sealing elements	BU9593/ HDR
502.01	Casing wear ring, suction side	Grey cast iron EN-GJL-250 / CI
502.02	Casing wear ring, discharge side	Grey cast iron EN-GJL-250 / CI
902	Studs	8.8/ 5.8
903	Plug	Steel
920	Nut	8 + A2A/ 8 + B633 SC1 TP
920	Impeller nut	8
		A4/ AISI316

Coating and preservation

- Coating and preservation to KSB standard

Product benefits

- Improved efficiency and NPSHreq by experimentally verified hydraulic design of impellers (vanes)
- Operating costs reduced by trimming the nominal impeller diameter to match the specified duty point
- Little wear, low vibration levels and excellent smooth running characteristics thanks to good suction performance and virtually cavitation-free operation across a wide operating range
- Casing sealed reliably – even in varying operating conditions – by confined casing gasket
- Extended selection chart with additional pump sizes for small flow rates
- Easy to dismantle due to back pull-out design; no need to remove the pump casing from the piping

Acceptance tests and warranty

The following acceptance tests may be performed at a surcharge:

- **Materials testing**
 - Test report 2.2
- **Final inspection**
 - Inspection certificate 3.1 to EN 10204
- **Hydraulic test**
 - The duty point of each pump is guaranteed according to ISO 9906/2B or ISO 9906/3B.
 - NPSH test
- Other inspections/tests on request

Warranties

- Warranties are given within the scope of the valid delivery conditions.

Overview of product features / selection tables

Overview of variants

Other designs on request

Overview of Etanorm SYT / Etabloc SYT / Etaline SYT variants

Design	102 / Volute casing	230 / Impeller	Mechanical seal	T [°C]	Main applications											
					Chemical industry / pharmaceutical industry	Plastic processing	Timber industry / paper industry / cardboard industry	Soap industry / laundry agent industry	Food industry	Textile industry	Mineral oil industry	Bitumen industry / tar processing industry	Metal processing industry	Aluminium industry		
SG08	Nodular cast iron EN-GJS-400-15/ 536 Gr. 60-40-18	Grey cast iron EN-GJL-250/ A 48 Cl. 35B	Mech. seal AQ1V7GG	$\geq -30 - \leq +180^{6) / 350^{7)}$	X	X	X	X	X	X	X	X	X	X	X	
SC08	Nodular cast iron EN-GJS-400-15/ 536 Gr. 60-40-18	Chrome steel 1.4408/ A 743 Gr. CF8M	Mech. seal AQ1V7GG	$\geq -30 - \leq +180^{6) / 350^{7)}$	X	X	X	X	X	X	X	X	X	X	X	

1172.51/03-EN

⁶ High-temperature hot water

⁷ Thermal oil

Overview of fluids handled

KSB EasySelect, selection software for all applications



KSB EasySelect is a comprehensive selection tool for all applications. It guides users to an optimal solution for their projects by offering a fast, easy and user-friendly way to select and configure pumps and valves. All that is required are some project-specific criteria and a few minutes' time. The tool systematically guides the user through KSB's wide range of products to the right product for the application at hand.

https://www.ksb.com/ksb-en/Select_your_pumps_and_valves/ksb-easyselect/

Other fluids upon request.

Excerpt from the overview of fluids handled with associated material variants

Fluid handled	Application limits ⁸⁾	Materials		Shaft seal
		Casing/impeller		Single mechanical seal
		Nodular cast iron/ grey cast iron	Nodular cast iron/ stainless steel	AQ1V7GG
		SG	SC	Code 08
High-temperature hot water ⁹⁾	t ≤ +180 °C p ≤ 16 bar	X		X
Thermal oil on mineral oil basis	t ≤ -30 to +350 °C p ≤ 16 bar	X		X
Thermal oil on synthetic basis, vaporisation pressure ≤ 1 bar at operating temperature ¹⁰⁾	t ≤ -30 to +350 °C p ≤ 16 bar	X		X

⁸⁾ The inlet pressure must not fall below atmospheric pressure.

⁹⁾ Low-salt and fully desalinated water to VdTÜV technical instruction leaflet / AGFW technical instruction leaflet TCN 1466 (VdTÜV) 5/15 (AGFW), edition 02.89

¹⁰⁾ For vaporisation pressure > 1 bar use an Etanorm SYT pump.

Overview of functions

Overview of functions

Functions / firmware	PumpDrive 2	PumpDrive 2 Eco
Protective functions		
Thermal motor protection	X	X
Mains voltage monitoring	X	X
Phase failure, motor side	X	X
Short-circuit monitoring, motor side (phase to phase and phase to earth)	X	X
Dynamic overload protection by speed limitation (i ² t control)	X	X
Resonant frequency suppression	X	X
Broken wire detection (live zero)	X	X
Protection against dry running and hydraulic blockage (sensorless due to learning function)	X	X
Dry running protection (external control signal)	X	X
Operating point estimation and characteristic curve control	X	X
Open-loop control		
Open-loop control mode	X	X
Closed-loop control		
Closed-loop control mode via integrated PID controller	X	X
Pressure control / differential pressure control (Δp const)	X	X
Pressure control / differential pressure control with dynamic pressure compensation (Δp var)	X	X
Flow rate control	X	X
Sensorless differential pressure control (Δp const) in a single-pump configuration	X	X
Sensorless differential pressure control with dynamic pressure compensation (Δp var) in a single-pump configuration	X	X
Sensorless flow rate control	X	X
Level control	X	X
Temperature control	X	X
Alternative setpoint	X	-
Operation and monitoring (display)		
Measured value display (pressure, head, speed, electric power, motor voltage, motor current, torque)	X	X
Fault history	X	X
Operating hours counter	X	X
Fault reporting via relay	X	X
Frequency inverter functions		
Programmable start ramps and stop ramps	X	X
Field-oriented control (vector control), V/f control	X	X
Configurable motor control method (asynchronous motor, KSB SuPremE)	X	X
Automatic motor adaptation (AMA)	X	X
Motor standstill heater	X	X
Manual-0-automatic mode	X	X
External OFF	X	X
External minimum speed	X	X
Sleep mode (stand-by mode)	X	X
Energy savings meter	X	-
Pump functions		
Flow rate estimation	X	X
M12 module with PumpMeter bus connection	X	X
M12 module for dual-pump configuration	X	X
M12 module for multiple pump configuration with up to 6 pumps	X	X
Functional check run	X	X
Deragging	X	X
Integrated dual-pump configuration (1x100 % with redundant pump or 2x50 % without redundant pump)	X	X
Multiple pump configuration with up to 6 pumps	X	X
Waste water function: start-up at maximum speed	X	-
Waste water function: rinsing function	X	-
Operation		

Functions / firmware	PumpDrive 2	PumpDrive 2 Eco
Control panel	X	X ¹¹⁾
Commissioning wizard	X	X ¹²⁾
Favourites list	X	-
Service interface	X	X

¹¹ Some functions can only be parameterised and/or displayed using the KSB ServiceTool (see operating manual).
¹² Only available via KSB ServiceTool or app

Pressure and temperature limits

Test pressure limits and temperature limits

Test pressure limits and temperature limits depending on the material

Material	Fluid temperature	Test pressure ¹³⁾
	[°C]	[bar]
S	-30 to +350	≤ 25

In-service pressure limits and temperature limits

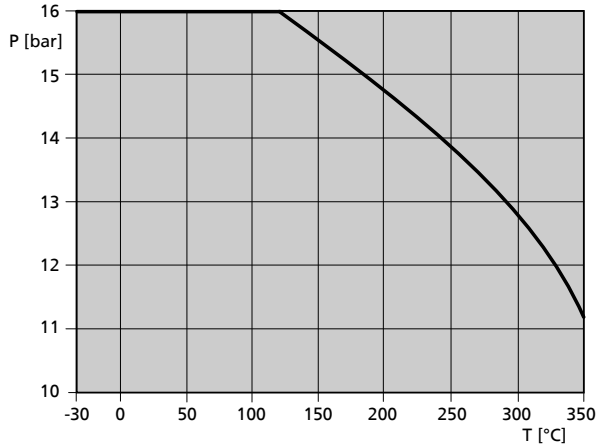

Fig. 1: Operating pressure limits and temperature limits

Technical data

Etabloc SYT

Technical data

Etabloc SYT	Shaft unit	Impeller				Speed limit	
		Outlet	Inlet	Nominal diameter		Max.	Min.
			Diameter	Max.	Min.		
[mm]						[rpm]	
040-025-160	25	6,0	45,2	169	130	3600	800
040-025-200	25	6,0	45,2	209	160	3600	800
050-032-125.1	25	6,6	52,4	139	104	3600	800
050-032-160	25	8,5	60,6	174	136	3600	800
050-032-160.1	25	5,7	52,7	170	136	4400	800
050-032-200	25	7,0	62,9	209	170	3700	800
050-032-200.1	25	5,6	54,0	204	170	3800	800
065-040-160	25	13,0	70,0	174	128	4400	800
065-040-200	25	9,4	69,4	209	165	3700	800
065-050-160	25	16,9	86,9	174	128	4400	800
065-050-200	25	13,8	83,1	219	170	3600	800
080-065-160	25	21,0	92,0	174	132	3900	800
080-065-200	25	17,0	99,7	219	175	3600	800
100-080-160	25	31,6	124,0	174	138	3600	800

1172.51/03-EN

¹³ The casing components are checked for leakage by means of internal pressure tests to AN 1897/75-03D00 with water.

Selection charts

Etabloc SYT (fixed speed version), n = 2900 rpm

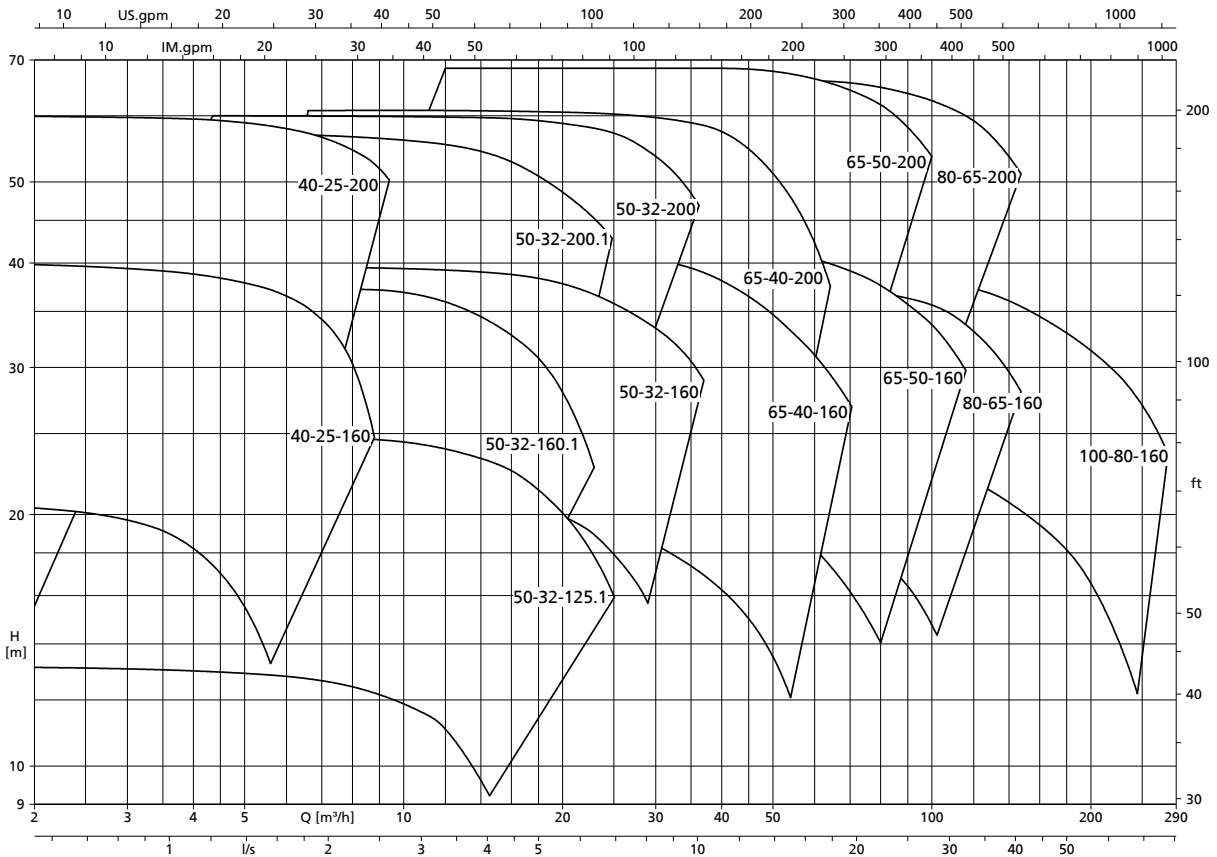

Etabloc SYT (fixed speed version), n = 1450 rpm

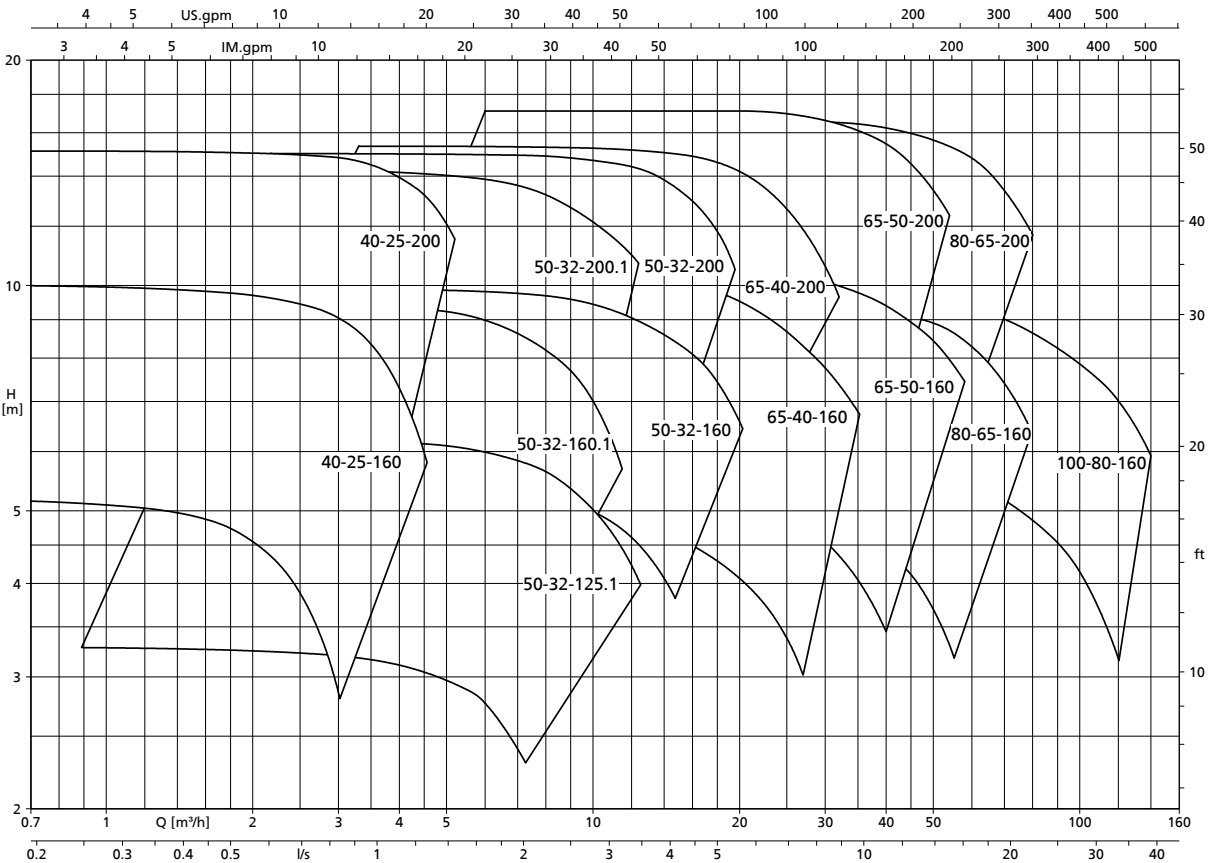

1172.51/03-EN

Etabloc SYT (fixed speed version), n = 3500 rpm

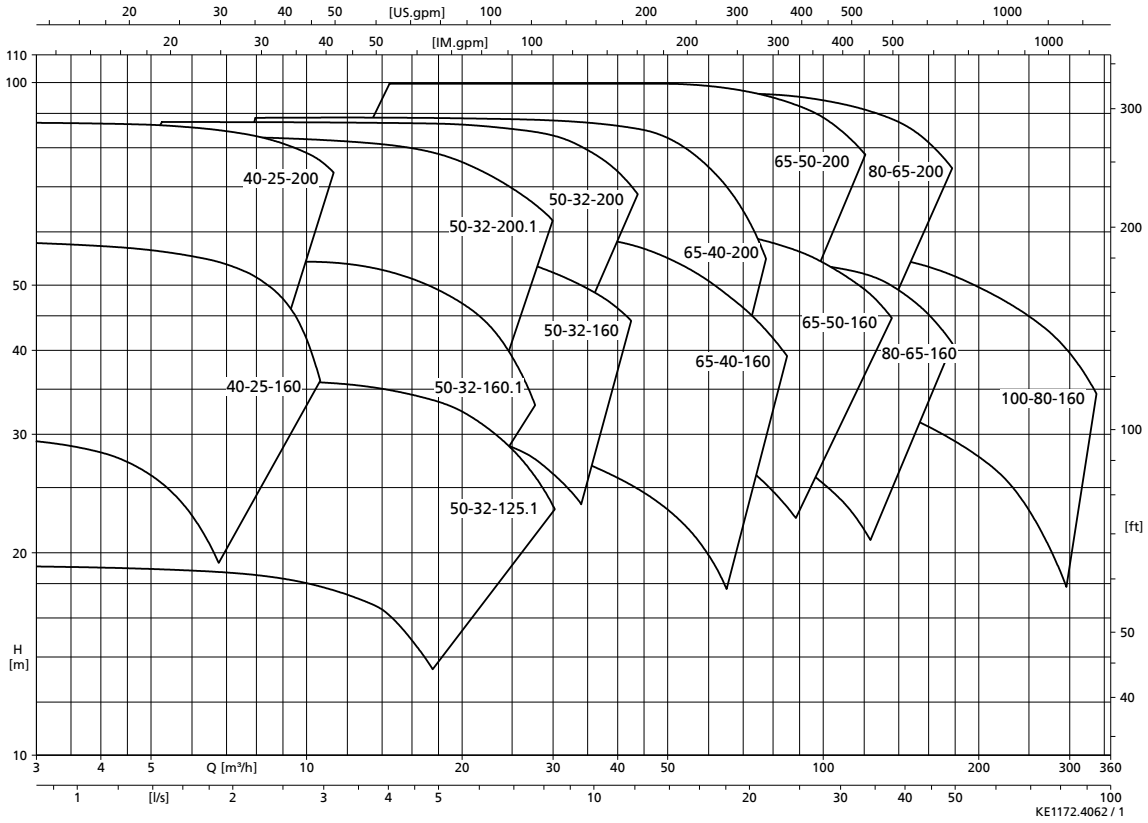

Etabloc SYT (fixed speed version), n = 1750 rpm

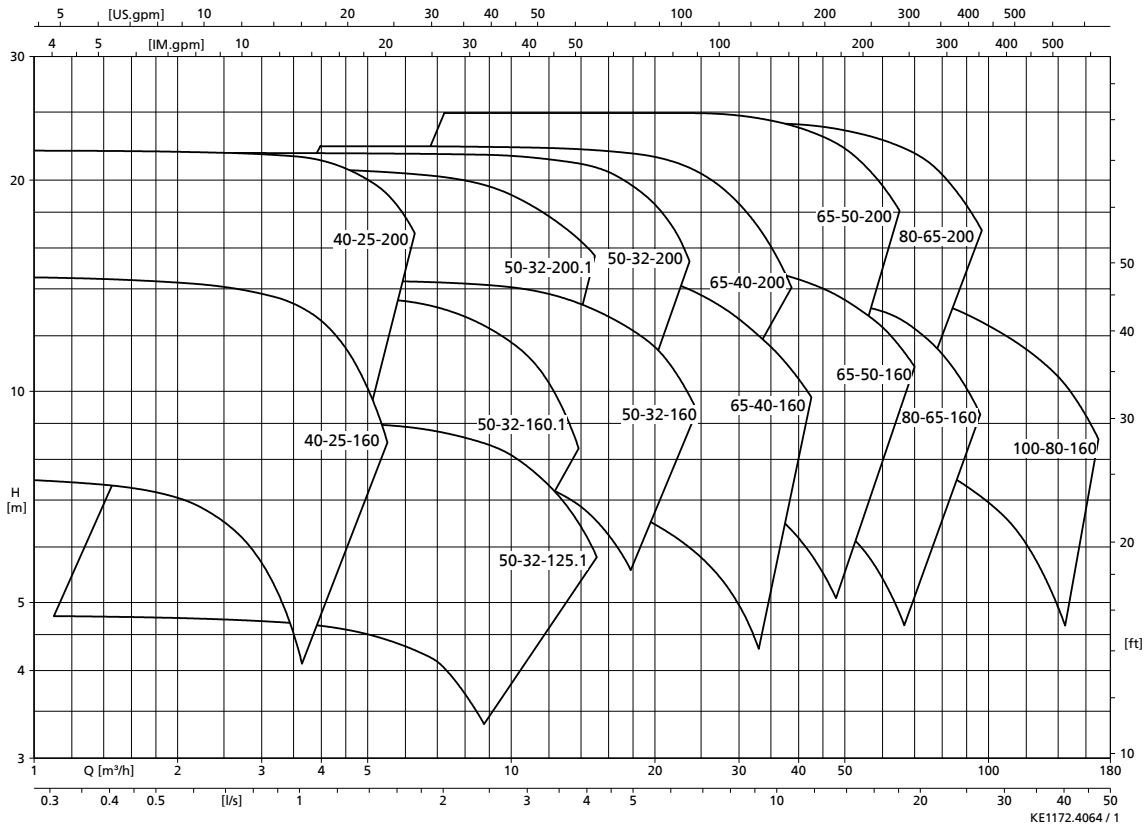

1172.51/03-EN

Dimensions and connections

Pump set (fixed speed version), $n = 2900 \text{ rpm} / 3500 \text{ rpm}$

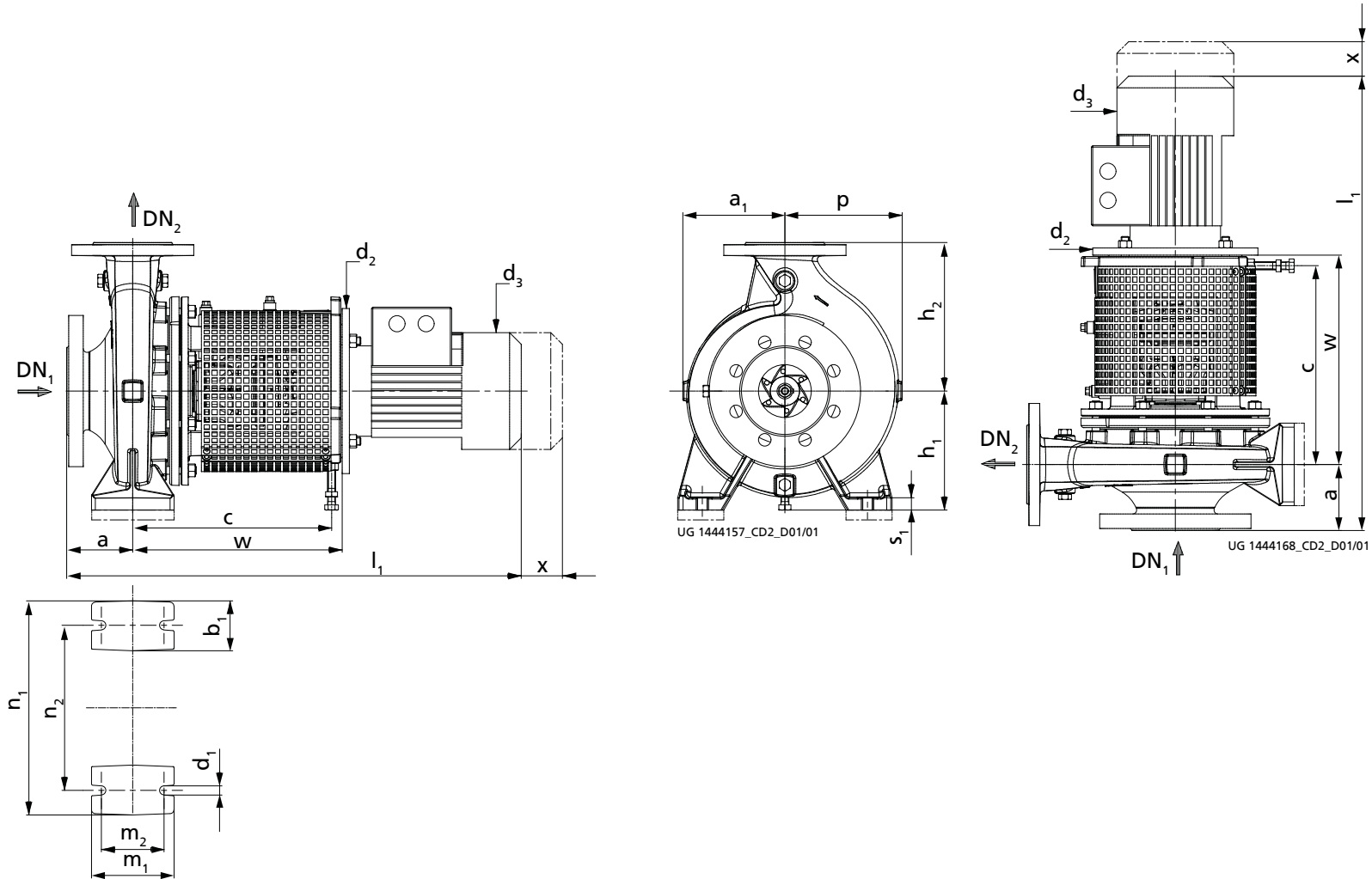

Fig. 2: Dimensions of Etabloc SYT, $n = 2900 \text{ rpm} / n = 3500 \text{ rpm}$

Dimensions

Etabloc SYT n = 2900 rpm n = 3500 rpm	Motor	P		I _N	DN ₁	DN ₂	a	a ₁	b ₁	c	d ₁	d ₂	d ₃	h ₁	h ₂	l ₁	m ₁	m ₂	n ₁	n ₂	p	s ₁	w	x
		50 Hz	60 Hz	400 V																				
				50 Hz																				
		[kW]	[kW]	[~A]	[mm]																			
040-025-160	80M	0,75	-	1,75	40	25	80	118	50	301	14	200	162	132	160	657	100	70	240	190	118	15	322	100
040-025-160	80M	1,10	1,27	2,41	40	25	80	118	50	301	14	200	162	132	160	671	100	70	240	190	118	15	322	100
040-025-160	90S	1,50	1,75	3,15	40	25	80	118	50	301	14	200	190	132	160	684	100	70	240	190	118	15	322	100
040-025-160	90L	2,20	2,55	4,46	40	25	80	118	50	301	14	200	190	132	160	710	100	70	240	190	118	15	322	100
040-025-160	100L	-	3,45	6,09	40	25	80	118	50	301	14	250	213	132	160	744	100	70	240	190	118	15	317	100
040-025-160	112M	-	4,55	7,82	40	25	80	118	50	301	14	250	234	132	160	768	100	70	240	190	118	15	317	100
040-025-200	90S	1,50	-	3,15	40	25	80	142	50	301	14	200	190	160	180	684	100	70	240	190	142	15	322	100
040-025-200	90L	2,20	-	4,46	40	25	80	142	50	301	14	200	190	160	180	710	100	70	240	190	142	15	322	100
040-025-200	100L	3,00	3,45	6,09	40	25	80	142	50	301	14	250	213	160	180	744	100	70	240	190	142	15	317	100
040-025-200	112M	4,00	4,55	7,82	40	25	80	142	50	301	14	250	234	160	180	768	100	70	240	190	142	15	317	100
040-025-200	132S	5,50	6,30	10,49	40	25	80	142	50	324	14	300	266	160	180	833	100	70	240	190	142	15	340	100
040-025-200	132S	-	8,60	14,12	40	25	80	142	50	324	14	300	266	160	180	833	100	70	240	190	142	15	340	100
050-032-125.1	80M	0,75	-	1,75	50	32	80	116	50	301	14	200	162	112 ¹⁴⁾	140	657	100	70	190	140	116	15	322	100
050-032-125.1	80M	1,10	-	2,41	50	32	80	116	50	301	14	200	162	112 ¹⁴⁾	140	671	100	70	190	140	116	15	322	100
050-032-125.1	90S	1,50	-	3,15	50	32	80	116	50	301	14	200	190	112 ¹⁴⁾	140	684	100	70	190	140	116	15	322	100
050-032-125.1	90L	2,20	-	4,46	50	32	80	116	50	301	14	200	190	112 ¹⁴⁾	140	710	100	70	190	140	116	15	322	100
050-032-125.1	100L	-	3,45	6,09	50	32	80	116	50	301	14	250	213	112 ¹⁴⁾	140	744	100	70	190	140	116	15	317	100
050-032-125.1	112M	-	4,55	7,82	50	32	80	116	50	301	14	250	234	112 ¹⁴⁾	140	768	100	70	190	140	116	15	317	100
050-032-125.1	132S	-	6,30	10,49	50	32	80	116	50	324	14	300	266	112 ¹⁵⁾	140	833	100	70	190	140	116	15	340	100
050-032-160	90L	2,20	-	4,46	50	32	80	118	50	301	14	200	190	132	160	710	100	70	240	190	128	15	322	100
050-032-160	100L	3,00	3,45	6,09	50	32	80	118	50	301	14	250	213	132	160	744	100	70	240	190	128	15	317	100
050-032-160	112M	4,00	4,55	7,82	50	32	80	118	50	301	14	250	234	132	160	768	100	70	240	190	128	15	317	100
050-032-160	132S	-	6,30	10,49	50	32	80	118	50	324	14	300	266	132 ¹⁴⁾	160	833	100	70	240	190	128	15	340	100
050-032-160	132S	-	8,60	14,12	50	32	80	118	50	324	14	300	266	132 ¹⁴⁾	160	833	100	70	240	190	128	15	340	100
050-032-160.1	90S	1,50	-	3,15	50	32	80	116	50	301	14	200	190	132	160	684	100	70	240	190	121	15	322	100
050-032-160.1	90L	2,20	2,55	4,46	50	32	80	116	50	301	14	200	190	132	160	710	100	70	240	190	121	15	322	100
050-032-160.1	100L	3,00	3,45	6,09	50	32	80	116	50	301	14	250	213	132	160	744	100	70	240	190	121	15	317	100
050-032-160.1	112M	4,00	4,55	7,82	50	32	80	116	50	301	14	250	234	132	160	768	100	70	240	190	121	15	317	100
050-032-160.1	132S	-	6,30	10,49	50	32	80	116	50	324	14	300	266	132 ¹⁴⁾	160	833	100	70	240	190	121	15	340	100
050-032-160.1	132S	-	8,60	14,12	50	32	80	116	50	324	14	300	266	132 ¹⁴⁾	160	833	100	70	240	190	121	15	340	100

¹⁴ Pump feet shimmed 20 mm¹⁵ Pump feet shimmed 40 mm

Etabloc SYT n = 2900 rpm n = 3500 rpm	Motor	P			I _N	DN ₁	DN ₂	a	a ₁	b ₁	c	d ₁	d ₂	d ₃	h ₁	h ₂	l ₁	m ₁	m ₂	n ₁	n ₂	p	s ₁	w	x
		50 Hz	60 Hz	400 V																					
				50 Hz																					
		[kW]	[kW]	[~A]																					
[mm]																									
050-032-160.1	160M	-	12,6	20,41	50	32	80	116	50	356	14	300	325	132 ¹⁶⁾	160	1000	100	70	240	190	121	15	374	100	
050-032-200	112M	4,00	-	7,82	50	32	80	142	50	301	14	250	234	160	180	768	100	70	240	190	143	18	317	100	
050-032-200	132S	5,50	-	10,49	50	32	80	142	50	324	14	300	266	160	180	833	100	70	240	190	143	18	340	100	
050-032-200	132S	7,50	8,60	14,12	50	32	80	142	50	324	14	300	266	160	180	833	100	70	240	190	143	18	340	100	
050-032-200	160M	11,0	12,6	20,41	50	32	80	142	50	356	14	350	325	160 ¹⁴⁾	180	1000	100	70	240	190	143	18	374	100	
050-032-200	160M	-	17,3	27,25	50	32	80	142	50	356	14	350	325	160 ¹⁴⁾	180	1000	100	70	240	190	143	18	374	100	
050-032-200.1	100L	3,00	-	6,09	50	32	80	142	50	301	14	250	213	160	180	744	100	70	240	190	142	18	317	100	
050-032-200.1	112M	4,00	-	7,82	50	32	80	142	50	301	14	250	234	160	180	768	100	70	240	190	142	18	317	100	
050-032-200.1	132S	5,50	6,30	10,49	50	32	80	142	50	324	14	300	266	160	180	833	100	70	240	190	142	18	340	100	
050-032-200.1	132S	7,50	8,60	14,12	50	32	80	142	50	324	14	300	266	160	180	833	100	70	240	190	142	18	340	100	
050-032-200.1	160M	-	12,6	20,41	50	32	80	142	50	356	14	350	325	160 ¹⁴⁾	180	1000	100	70	240	190	142	18	374	100	
050-032-200.1	160M	-	17,3	27,25	50	32	80	142	50	356	14	350	325	160 ¹⁴⁾	180	1000	100	70	240	190	142	18	374	100	
065-040-160	100L	3,00	-	6,09	65	40	80	119	50	301	14	250	213	132	160	744	100	70	240	190	134	15	317	100	
065-040-160	112M	4,00	-	7,82	65	40	80	119	50	301	14	250	234	132	160	768	100	70	240	190	134	15	317	100	
065-040-160	132S	5,50	6,30	10,49	65	40	80	119	50	324	14	300	266	132 ¹⁴⁾	160	833	100	70	240	190	134	15	340	100	
065-040-160	132S	7,50	8,60	14,12	65	40	80	119	50	324	14	300	266	132 ¹⁴⁾	160	833	100	70	240	190	134	15	340	100	
065-040-160	160M	-	12,6	20,41	65	40	80	119	50	356	14	350	325	132 ¹⁷⁾	160	1000	100	70	240	190	134	15	374	100	
065-040-160	160M	-	17,3	27,25	65	40	80	119	50	356	14	350	325	132 ¹⁷⁾	160	1000	100	70	240	190	134	15	374	100	
065-040-200	132S	5,50	-	10,49	65	40	100	142	50	324	14	300	266	160	180	853	100	70	265	212	155	18	340	100	
065-040-200	132S	7,50	-	14,12	65	40	100	142	50	324	14	300	266	160	180	853	100	70	265	212	155	18	340	100	
065-040-200	160M	11,0	12,6	20,41	65	40	100	142	50	356	14	350	325	160 ¹⁴⁾	180	1020	100	70	265	212	155	18	374	100	
065-040-200	160M	15,0	17,3	27,25	65	40	100	142	50	356	14	350	325	160 ¹⁴⁾	180	1020	100	70	265	212	155	18	374	100	
065-040-200	160L	18,5	21,3	33,38	65	40	100	142	50	356	14	350	325	160 ¹⁴⁾	180	1026	100	70	265	212	155	18	374	100	
065-040-200	180M	22,0	24,5	39,52	65	40	100	142	50	356	14	350	370	160 ¹⁴⁾	180	1084	100	70	265	212	155	18	374	100	
065-050-160	132S	5,50	-	10,49	65	50	100	128	50	324	14	300	266	160	180	853	100	70	265	212	149	18	340	100	
065-050-160	132S	7,50	-	14,12	65	50	100	128	50	324	14	300	266	160	180	853	100	70	265	212	149	18	340	100	
065-050-160	160M	11,0	12,6	20,41	65	50	100	128	50	356	14	350	325	160 ¹⁴⁾	180	1020	100	70	265	212	149	18	374	100	
065-050-160	160M	-	17,3	27,25	65	50	100	128	50	356	14	350	325	160 ¹⁴⁾	180	1020	100	70	265	212	149	18	374	100	
065-050-160	160L	-	21,3	33,38	65	50	100	128	50	356	14	350	325	160 ¹⁴⁾	180	1026	100	70	265	212	149	18	374	100	
065-050-160	180M	-	24,5	39,52	65	50	100	128	50	356	14	350	370	160 ¹⁴⁾	180	1084	100	70	265	212	149	18	374	100	
065-050-200	160M	11,0	-	20,41	65	50	100	144	50	356	14	350	325	160 ¹⁴⁾	200	1020	100	70	265	212	163	18	374	100	

¹⁶ Pump feet shimmed 50 mm¹⁷ Pump feet shimmed 30 mm

Etabloc SYT n = 2900 rpm n = 3500 rpm	Motor	P			I _N	DN ₁	DN ₂	a	a ₁	b ₁	c	d ₁	d ₂	d ₃	h ₁	h ₂	l ₁	m ₁	m ₂	n ₁	n ₂	p	s ₁	w	x
		50 Hz	60 Hz	400 V																					
				50 Hz																					
		[kW]	[kW]	[~A]	[mm]																				
065-050-200	160M	15,0	-	27,25	65	50	100	144	50	356	14	350	325	160 ¹⁴⁾	200	1020	100	70	265	212	163	18	374	100	
065-050-200	160L	18,5	-	33,38	65	50	100	144	50	356	14	350	325	160 ¹⁴⁾	200	1026	100	70	265	212	163	18	374	100	
065-050-200	180M	22,0	24,5	39,52	65	50	100	144	50	356	14	350	370	160 ¹⁴⁾	200	1084	100	70	265	212	163	18	374	100	
080-065-160	132S	7,50	-	14,12	80	65	100	132	65	324	14	300	266	160	200	853	125	95	280	212	160	18	340	100	
080-065-160	160M	11,0	-	20,41	80	65	100	132	65	356	14	350	325	160 ¹⁴⁾	200	1020	125	95	280	212	160	18	374	100	
080-065-160	160M	15,0	17,3	27,25	80	65	100	132	65	356	14	350	325	160 ¹⁴⁾	200	1020	125	95	280	212	160	18	374	100	
080-065-160	160L	-	21,3	33,38	80	65	100	132	65	356	14	350	325	160 ¹⁴⁾	200	1026	125	95	280	212	160	18	374	100	
080-065-160	180M	-	24,5	39,52	80	65	100	132	65	356	14	350	370	160 ¹⁴⁾	200	1084	125	95	280	212	160	18	374	100	
080-065-200	160M	15,0	-	27,25	80	65	100	155	65	356	14	350	325	180	225	1020	125	95	320	250	178	18	374	140	
080-065-200	160L	18,5	-	33,38	80	65	100	155	65	356	14	350	325	180	225	1026	125	95	320	250	178	18	374	140	
080-065-200	180M	22,0	24,5	39,52	80	65	100	155	65	356	14	350	370	180	225	1084	125	95	320	250	178	18	374	140	
100-080-160	160M	15,0	-	27,25	100	80	125	138	65	356	14	350	325	180	225	1045	125	95	320	250	174	18	374	140	
100-080-160	160L	18,5	-	33,38	100	80	125	138	65	356	14	350	325	180	225	1051	125	95	320	250	174	18	374	140	
100-080-160	180M	22,0	24,5	39,52	100	80	125	138	65	356	14	350	370	180	225	1109	125	95	320	250	174	18	374	140	

Pump set (fixed speed version), $n = 1450 \text{ rpm} / 1750 \text{ rpm}$

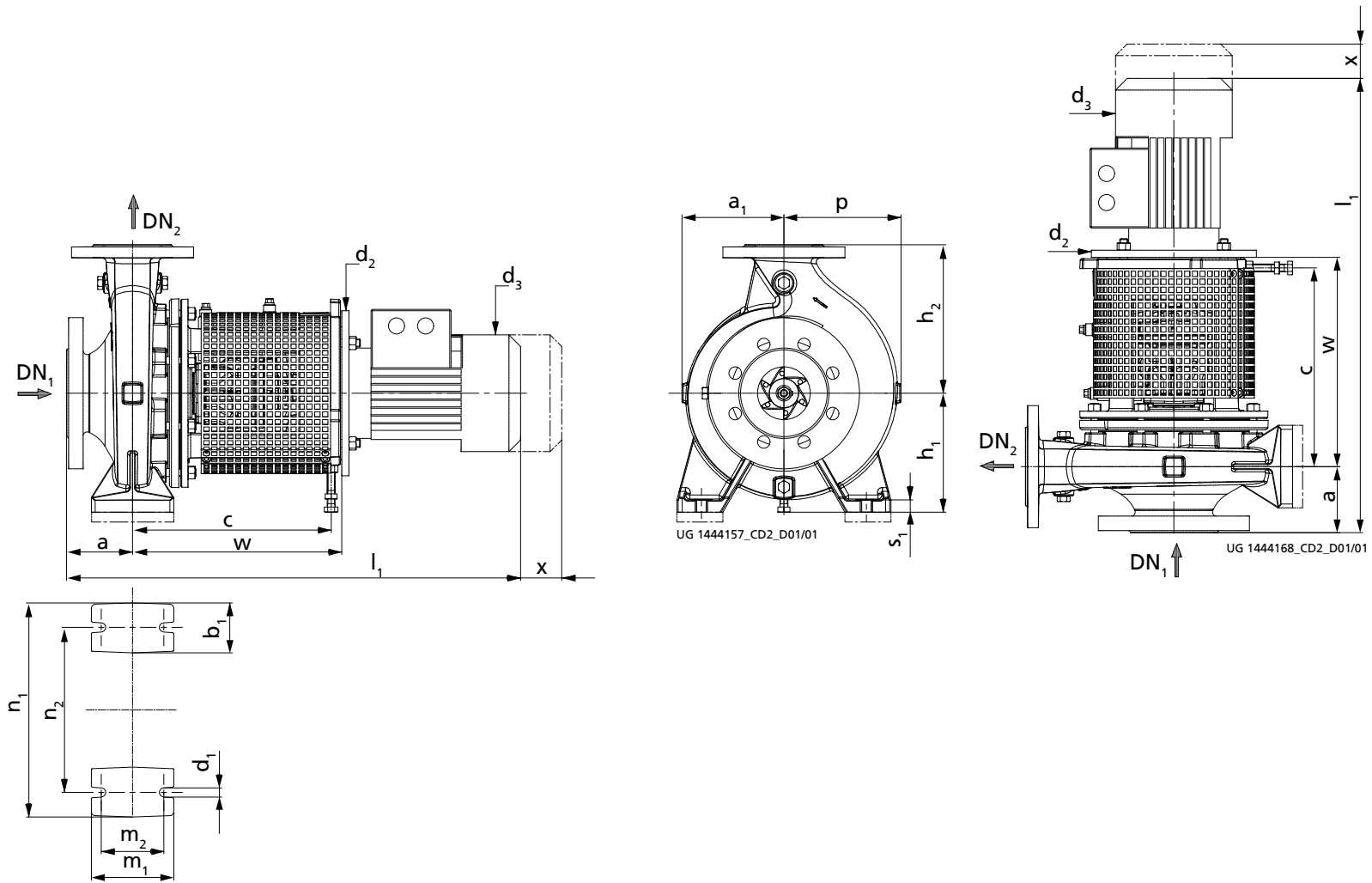

Fig. 3: Dimensions of Etabloc SYT, $n = 1450 \text{ rpm} / n = 1750 \text{ rpm}$

Dimensions

Etabloc SYT n = 1450 rpm n = 1750 rpm	Motor	P			I _N	DN ₁	DN ₂	a	a ₁	b ₁	c	d ₁	d ₂	d ₃	h ₁	h ₂	l ₁	m ₁	m ₂	n ₁	n ₂	p	s ₁	w	x
		50 Hz	60 Hz	400 V																					
				50 Hz																					
		[kW]	[kW]	[~A]	[mm]																				
040-025-160	80M	-	0,63	1,46	40	25	80	118	50	301	14	200	162	132	160	657	100	70	240	190	118	15	322	100	
040-025-160	90S	1,10	1,27	2,51	40	25	80	118	50	301	14	200	190	132	160	684	100	70	240	190	118	15	322	100	
040-025-200	80M	0,55	0,63	1,46	40	25	80	142	50	301	14	200	162	160	180	657	100	70	240	190	142	15	322	100	
040-025-200	80M	-	0,86	1,67	40	25	80	142	50	301	14	200	162	160	180	657	100	70	240	190	142	15	322	100	
040-025-200	90S	-	1,27	2,51	40	25	80	142	50	301	14	200	190	160	180	684	100	70	240	190	142	15	322	100	
050-032-125.1	80M	0,55	0,63	1,46	50	32	80	116	50	301	14	200	162	112 ¹⁸⁾	140	657	100	70	190	140	116	15	322	100	
050-032-125.1	90S	1,10	1,27	2,51	50	32	80	116	50	301	14	200	190	112 ¹⁸⁾	140	684	100	70	190	140	116	15	322	100	
050-032-160	80M	0,55	0,63	1,46	50	32	80	118	50	301	14	200	162	132	160	657	100	70	240	190	128	15	322	100	
050-032-160	80M	0,75	0,86	1,67	50	32	80	118	50	301	14	200	162	132	160	657	100	70	240	190	128	15	322	100	
050-032-160	90S	-	1,27	2,51	50	32	80	118	50	301	14	200	190	132	160	684	100	70	240	190	128	15	322	100	
050-032-160.1	80M	0,55	0,63	1,46	50	32	80	116	50	301	14	200	162	132	160	657	100	70	240	190	121	15	322	100	
050-032-160.1	80M	-	0,86	1,67	50	32	80	116	50	301	14	200	162	132	160	657	100	70	240	190	121	15	322	100	
050-032-200	80M	0,55	-	1,46	50	32	80	142	50	301	14	200	162	160	180	657	100	70	240	190	143	18	322	100	
050-032-200	80M	0,75	-	1,67	50	32	80	142	50	301	14	200	162	160	180	657	100	70	240	190	143	18	322	100	
050-032-200	90S	1,10	1,27	2,51	50	32	80	142	50	301	14	200	190	160	180	684	100	70	240	190	143	18	322	100	
050-032-200	90L	-	1,75	3,32	50	32	80	142	50	301	14	200	190	160	180	710	100	70	240	190	143	18	322	100	
050-032-200	100L	-	2,55	4,67	50	32	80	142	50	301	14	250	213	160	180	744	100	70	240	190	143	18	317	100	
050-032-200.1	80M	0,55	0,63	1,46	50	32	80	142	50	301	14	200	162	160	180	657	100	70	240	190	142	18	322	100	
050-032-200.1	80M	0,75	0,86	1,67	50	32	80	142	50	301	14	200	162	160	180	657	100	70	240	190	142	18	322	100	
050-032-200.1	90S	-	1,27	2,51	50	32	80	142	50	301	14	200	190	160	180	684	100	70	240	190	142	18	322	100	
050-032-200.1	90L	-	1,75	3,32	50	32	80	142	50	301	14	200	190	160	180	710	100	70	240	190	142	18	322	100	
065-040-160	80M	0,55	-	1,46	65	40	80	119	50	301	14	200	162	132	160	657	100	70	240	190	134	15	322	100	
065-040-160	80M	0,75	0,86	1,67	65	40	80	119	50	301	14	200	162	132	160	657	100	70	240	190	134	15	322	100	
065-040-160	90S	1,10	1,27	2,51	65	40	80	119	50	301	14	200	190	132	160	684	100	70	240	190	134	15	322	100	
065-040-160	90L	-	1,75	3,32	65	40	80	119	50	301	14	200	190	132	160	710	100	70	240	190	134	15	322	100	
065-040-160	100L	-	2,55	4,67	65	40	80	119	50	301	14	250	213	132	160	744	100	70	240	190	134	15	317	100	
065-040-200	80M	0,75	-	1,67	65	40	100	142	50	301	14	200	162	160	180	677	100	70	265	212	155	18	322	100	
065-040-200	90S	1,10	-	2,51	65	40	100	142	50	301	14	200	190	160	180	704	100	70	265	212	155	18	322	100	
065-040-200	90L	1,50	1,75	3,32	65	40	100	142	50	301	14	200	190	160	180	730	100	70	265	212	155	18	322	100	
065-040-200	100L	-	2,55	4,67	65	40	100	142	50	301	14	250	213	160	180	764	100	70	265	212	155	18	317	100	
065-040-200	100L	-	3,45	6,18	65	40	100	142	50	301	14	250	213	160	180	799	100	70	265	212	155	18	317	100	
065-050-160	80M	0,75	-	1,67	65	50	100	128	50	301	14	200	162	160	180	677	100	70	265	212	149	18	322	100	

¹⁸⁾ Pump feet shimmed 20 mm

Etabloc SYT n = 1450 rpm n = 1750 rpm	Motor	P			I _N	DN ₁	DN ₂	a	a ₁	b ₁	c	d ₁	d ₂	d ₃	h ₁	h ₂	l ₁	m ₁	m ₂	n ₁	n ₂	p	s ₁	w	x
		50 Hz	60 Hz	400 V																					
		[kW]	[kW]	[~A]	[mm]																				
065-050-160	90S	1,10	1,27	2,51	65	50	100	128	50	301	14	200	190	160	180	704	100	70	265	212	149	18	322	100	
065-050-160	90L	1,50	1,75	3,32	65	50	100	128	50	301	14	200	190	160	180	730	100	70	265	212	149	18	322	100	
065-050-160	100L	-	2,55	4,67	65	50	100	128	50	301	14	250	213	160	180	764	100	70	265	212	149	18	317	100	
065-050-160	100L	-	3,45	6,18	65	50	100	128	50	301	14	250	213	160	180	799	100	70	265	212	149	18	317	100	
065-050-200	90L	1,50	-	3,32	65	50	100	144	50	301	14	200	190	160	200	730	100	70	265	212	163	18	322	100	
065-050-200	100L	2,20	2,55	4,67	65	50	100	144	50	301	14	250	213	160	200	764	100	70	265	212	163	18	317	100	
065-050-200	100L	3,00	3,45	6,18	65	50	100	144	50	301	14	250	213	160	200	799	100	70	265	212	163	18	317	100	
065-050-200	112M	-	4,55	8,23	65	50	100	144	50	301	14	250	234	160	200	788	100	70	265	212	163	18	317	100	
065-050-200	132S	-	6,30	11,32	65	50	100	144	50	324	14	300	266	160	200	853	100	70	265	212	163	18	340	100	
080-065-160	90S	1,10	-	2,51	80	65	100	132	65	301	14	200	190	160	200	704	125	95	280	212	160	18	322	100	
080-065-160	90L	1,50	1,75	3,32	80	65	100	132	65	301	14	200	190	160	200	730	125	95	280	212	160	18	322	100	
080-065-160	100L	2,20	2,55	4,67	80	65	100	132	65	301	14	250	213	160	200	764	125	95	280	212	160	18	317	100	
080-065-160	100L	-	3,45	6,18	80	65	100	132	65	301	14	250	213	160	200	799	125	95	280	212	160	18	317	100	
080-065-160	112M	-	4,55	8,23	80	65	100	132	65	301	14	250	234	160	200	788	125	95	280	212	160	18	317	100	
080-065-160	132S	-	6,30	11,32	80	65	100	132	65	324	14	300	266	160	200	853	125	95	280	212	160	18	340	100	
080-065-200	100L	2,20	-	4,67	80	65	100	155	65	301	14	250	213	180	225	764	125	95	320	250	178	18	317	140	
080-065-200	100L	3,00	3,45	6,18	80	65	100	155	65	301	14	250	213	180	225	799	125	95	320	250	178	18	317	140	
080-065-200	112M	4,00	4,55	8,23	80	65	100	155	65	301	14	250	234	180	225	788	125	95	320	250	178	18	317	140	
080-065-200	132S	-	6,30	11,32	80	65	100	155	65	324	14	300	266	180	225	853	125	95	320	250	178	18	340	140	
080-065-200	132M	-	8,60	14,70	80	65	100	155	65	324	14	300	298	180	225	881	125	95	320	250	178	18	340	140	
100-080-160	90L	1,50	-	3,32	100	80	125	138	65	301	14	200	190	180	225	755	125	95	320	250	174	18	322	140	
100-080-160	100L	2,20	-	4,67	100	80	125	138	65	301	14	250	213	180	225	789	125	95	320	250	174	18	317	140	
100-080-160	100L	3,00	3,45	6,18	100	80	125	138	65	301	14	250	213	180	225	824	125	95	320	250	174	18	317	140	
100-080-160	112M	-	4,55	8,23	100	80	125	138	65	301	14	250	234	180	225	813	125	95	320	250	174	18	317	140	
100-080-160	132S	-	6,30	11,32	100	80	125	138	65	324	14	300	266	180	225	878	125	95	320	250	174	18	340	140	

Connections

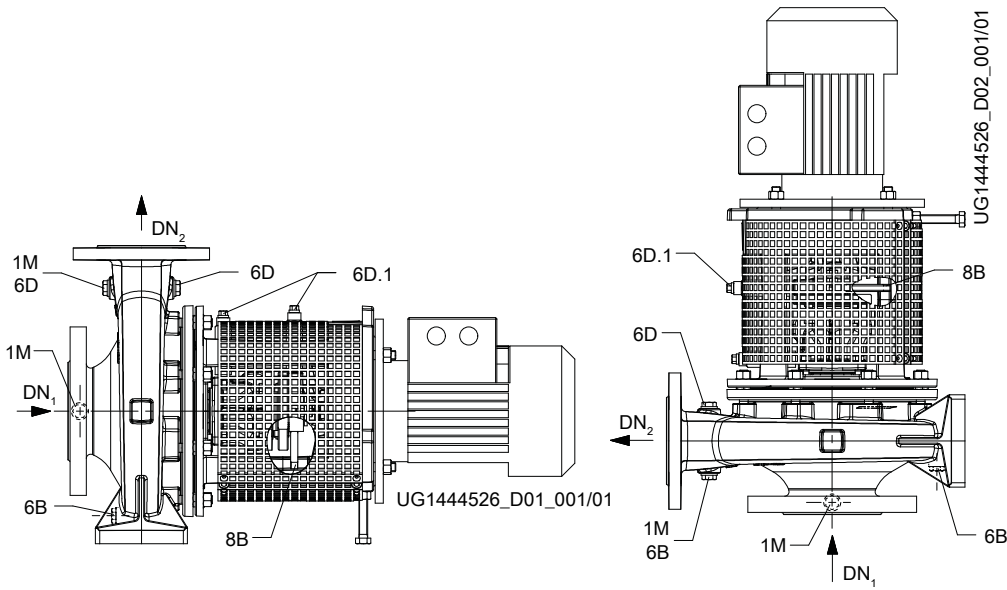

Fig. 4: Etabloc SYT connections by installation type

Connections

Connection	Description	Configuration	Position
1M	Connection for pressure gauge	Drilled and closed	Suction flange / discharge flange
6B	Fluid drain	Drilled and closed	Volute casing
6D, 6D.1	Fluid priming and venting	Drilled and closed	Volute casing / bearing housing
8B	Leakage drain	Drilled	Seal cover

Etabloc SYT connections

Etabloc SYT	Connection		
	Volute casing	Bearing housing / seal cover	
	1M, 6B, 6D	6D.1	8B
040-025-160	G 1/4	G 1/8	R 1/8
040-025-200	G 1/4	G 1/8	R 1/8
050-032-125.1	G 1/4	G 1/8	R 1/8
050-032-160	G 1/4	G 1/8	R 1/8
050-032-160.1	G 1/4	G 1/8	R 1/8
050-032-200	G 1/4	G 1/8	R 1/8
050-032-200.1	G 1/4	G 1/8	R 1/8
065-040-160	G 1/4	G 1/8	R 1/8
065-040-200	G 1/4	G 1/8	R 1/8
065-050-160	G 1/4	G 1/8	R 1/8
065-050-200	G 1/4	G 1/8	R 1/8
080-065-160	G 3/8	G 1/8	R 1/8
080-065-200	G 3/8	G 1/8	R 1/8
100-080-160	G 3/8	G 1/8	R 1/8

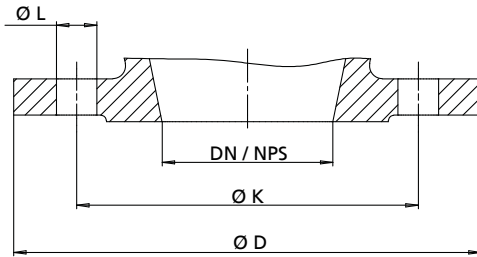
Flange design

Fig. 5: Flange dimensions of Etabloc SYT

Flange dimensions of Etabloc SYT

DN / NPS	Standard					
	EN 1092-2			ASME B 16.1		
	PN 16			Class 125		
	Ø K	Ø D	Number and Ø of holes (Ø L)	Ø K	Ø D	Number and Ø of holes (Ø L)
[mm]						
25 / NPS 1	85	115	4 × Ø14	79,2	115	4 × Ø15,7
32 / NPS 1 1/4	100	140	4 × Ø19	88,9	140	4 × Ø15,7
40 / NPS 1 1/2	110	150	4 × Ø19	98,6	150	4 × Ø15,7
50 / NPS 2	125	165	4 × Ø19	120,7	165	4 × Ø19,1
65 / NPS 2 1/2	145	185	4 × Ø19	139,7	185	4 × Ø19,1
80 ¹⁹⁾ / NPS 3	160	200 / 229 ²⁰⁾	8 × Ø19	152,4	200 / 229 ²⁰⁾	4 × Ø19,1
100 / NPS 4	180	230	8 × Ø19	190,5	230	8 × Ø19,1

NPS for DN 80 flange drilled to ASME table

Etabloc SYT	Bearing housing	Material	
		SG / SC	
		DN 1	DN 2
		ASME 125	ASME 125
080-065-160	25	NPS 4	NPS 2 1/2
080-065-200	25	NPS 4	NPS 2 1/2

Flange design by material

Material	Standard	Nominal size	Pressure class
S	EN 1092-2	DN 25 - DN 100	PN 16
	Drilled to ASME B16.1 ²¹⁾	DN 25 - DN 100	Class 125

¹⁹ DN 80 flange NPS 3 drilled to NPS 4 (Etabloc SYT 080-065-160 / 080-065-200), see "NPS for DN 80 flange drilled to ASME" table.

²⁰ Suction-side DN 80 flange (Etabloc SYT 080-065-160 / 080-065-200), see "NPS for DN 80 flange drilled to ASME" table.

²¹ DN 80 machined like DN 100

Installation types

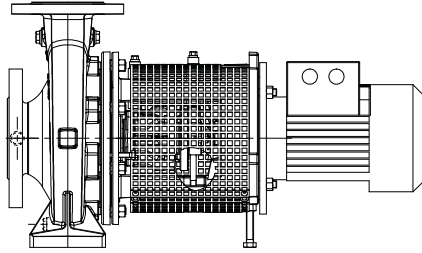

Fig. 6: Horizontal installation, Etabloc SYT

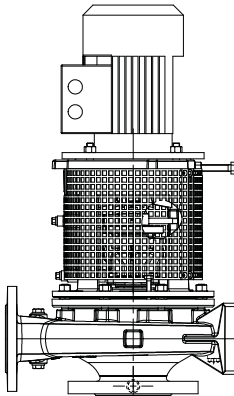

Fig. 7: Vertical installation, Etabloc SYT

Scope of supply

Depending on the model, the following items are included in the scope of supply:

- Pump
- Drive

General assembly drawings

Etabloc SYT exploded view

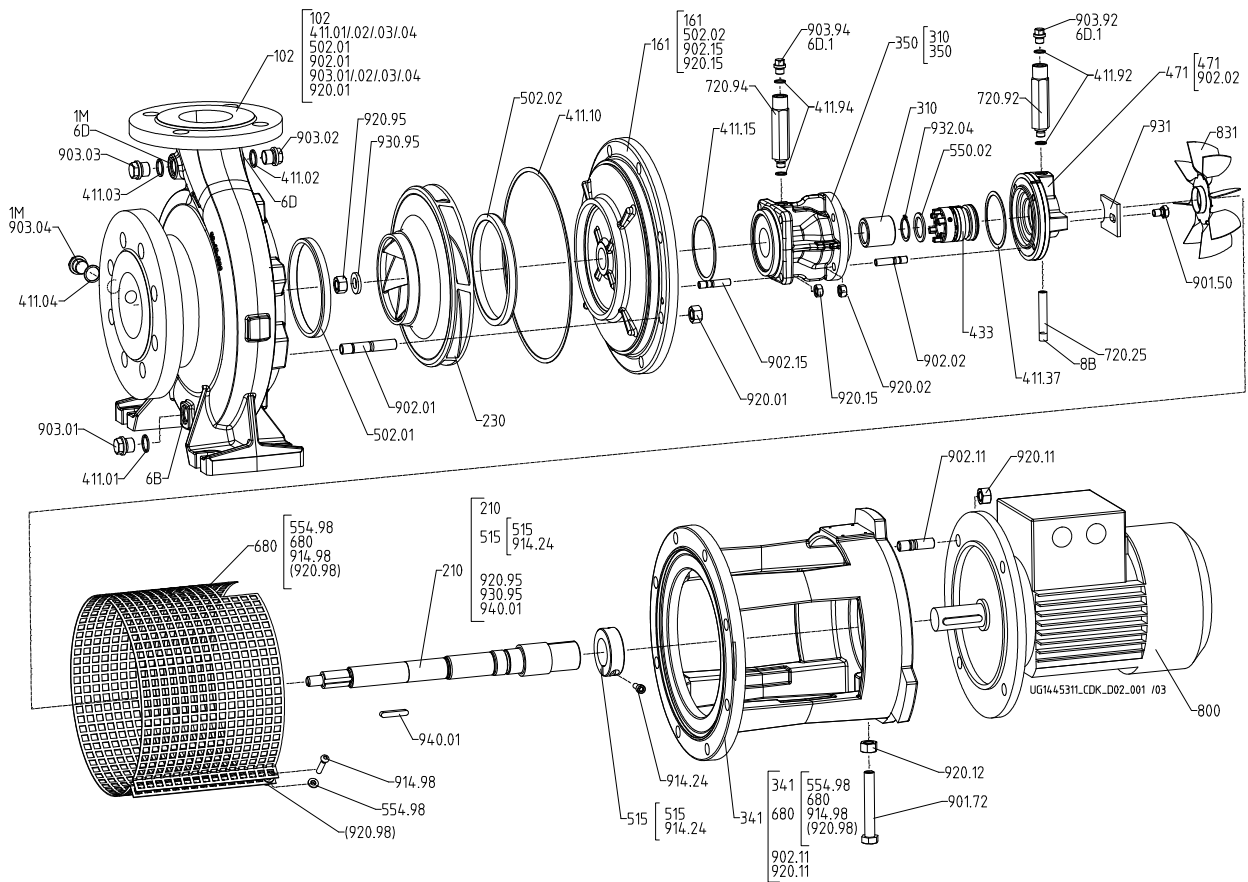

Fig. 8: Etabloc SYT exploded view

[Supplied in packaging units only
() Not available as individual spare part

List of components

Part No.	Description	Part No.	Description
102	Volute casing	720.25/.92/.94	Fitting
161	Casing cover	800	Motor
210	Shaft	831	Fan impeller
230	Impeller	901.50/.72	Hexagon head bolt
310	Plain bearing	902.01/.02/.11/.15	Stud
341	Drive lantern	903.01/.02/.03/.04/.92/.94	Screw plug
350	Bearing housing	914.24	Hexagon socket head cap screw
411.01/.02/.03/.04/.10/.15/.37/.92/.94	Joint ring	914.98	Pan head screw
433	Mechanical seal	920.01/.02/.11/.12/.15/.95	Hexagon nut
471	Seal cover	920.98	Blind rivet nut
502.01/.02	Casing wear ring	930.95	Nord-Lock bolt securing element
515	Taper lock ring	931	Lock washer
550.02	Disc	932.04	Circlip
554.98	Lock washer	940.01	Key
680	Guard		

Glossary

Back pull-out design

The complete back pull-out unit can be pulled out without having to remove the pump casing from the piping.

IE1

Efficiency class to IEC 60034-30: 1 = Standard Efficiency (IE = International Efficiency)

IE2

Efficiency class to IEC 60034-30: 2 = High Efficiency (IE = International Efficiency)

IE3

Efficiency class to IEC 60034-30: 3 = Premium Efficiency (IE = International Efficiency)

Mech. seal

Mechanical seal



KSB SE & Co. KGaA
Johann-Klein-Straße 9 • 67227 Frankenthal (Germany)
Tel. +49 6233 86-0
www.ksb.com